

SIXTH GRADE
MATH WITH
CONFIDENCE

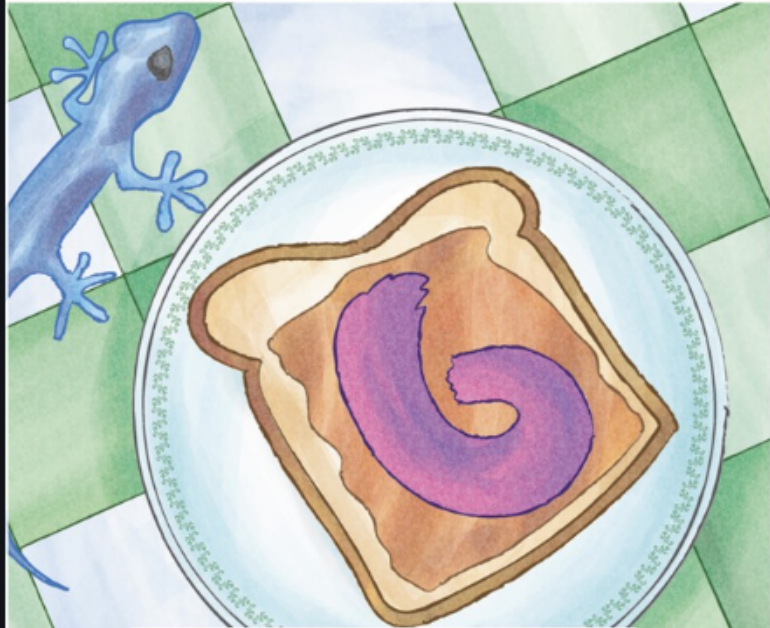

INSTRUCTOR GUIDE

FOR USE WITH STUDENT WORKBOOKS PART A AND PART B

KATE SNOW

Sixth Grade
Math
with Confidence

Instructor Guide

KATE SNOW

WELL-TRAINED MIND PRESS

Table of Contents

Welcome to <i>Sixth Grade Math with Confidence!</i>	1
Introduction	2
Unit 1: Order of Operations, Exponents, and Prime Factors	11
Unit 2: Review Fractions	59
Unit 3: Area of Parallelograms and Triangles	93
Unit 4: Ratios	123
Unit 5: Multiply Fractions and Mixed Numbers	157
Unit 6: Positive and Negative Numbers on the Number Line and Coordinate Plane	181
Unit 7: Divide Fractions and Mixed Numbers	207
Unit 8: Review Decimals	241
Unit 9: Expressions	273
Unit 10: Percentages	297
Unit 11: Equations	331
Unit 12: Volume	355
Unit 13: Surface Area	381
Unit 14: Rate and Speed	403
Unit 15: Multiply and Divide Decimals	429
Unit 16: Data and Statistics	469
Helpful Resources	509
Complete Memory Work List.....	509
Scope and Sequence.....	513
Materials List.....	516
Blackline Masters	518

Welcome to Sixth Grade Math with Confidence!

Sixth Grade Math with Confidence is a **complete, hands-on, and fun** math curriculum that will give your child a solid foundation in math. Your child will learn the following sixth-grade math skills:

- exponents and the order of operations
- adding, subtracting, multiplying, and dividing fractions and decimals
- ratios and rates
- percentages
- positive and negative integers and the coordinate plane
- evaluating expressions and solving simple equations with variables
- area of triangles and parallelograms
- volume and surface area
- data and statistics

The incremental, confidence-building lessons will help your child develop a strong understanding of math, step by step. Plus, daily review ensures he fully masters what he has learned in previous lessons. With this blend of **deep conceptual understanding** and **traditional skill practice**, you'll give your child a thorough sixth-grade math education.

Like the earlier levels of *Math with Confidence*, you'll find many hands-on activities and fun games to help your child develop a **positive attitude** toward math. You'll also find more written explanations and examples to help your child develop math study skills and begin to complete his math lessons more independently.

Besides this Instructor Guide, *Sixth Grade Math with Confidence* also includes **two colorful, engaging Student Workbooks**. You'll need both workbooks to complete the program. Workbook Part A covers Units 1-8, and Workbook Part B covers Units 9-16.

Many parents worry about their ability to teach math as their children move into more challenging topics like percentages and ratios. If that's the case for you, don't worry: I promise to guide you every step of the way! *Sixth Grade Math with Confidence* is full of features that will help you teach math with confidence all year long:

- **Scripted, open-and-go lessons** help you clearly explain and teach new math concepts.
- **Explanatory notes** help you understand more deeply how children learn math so you feel well-equipped to teach your child.
- **Unit Wrap-ups and Checkpoints** at the end of each unit provide assessment and give you guidance on whether your child is ready to move on to the next unit.

In the next section, you'll learn how the curriculum is organized and how to get your materials ready. Invest a little time reading this section now (and getting your Math Kit ready), and you'll be ready to teach math like a pro all year long.

Wishing you a joyful year of sixth-grade math!
Kate Snow

Introduction

The Goals of *Sixth Grade Math with Confidence*

Sixth Grade Math with Confidence aims to help children become confident and capable math students, with a deep understanding of math concepts, proficiency and fluency with fundamental skills, and a positive attitude toward math.

Deep Conceptual Understanding

You'll focus on one main topic per unit so your child can build deep conceptual knowledge of the new material. (Educators call this a *mastery approach* to new content.) Each new lesson builds on the previous one so your child gradually develops thorough understanding.

Proficiency with Fundamental Skills

Children need lots of practice to master the basic skills necessary for proficiency in math. *Sixth Grade Math with Confidence* provides continual, ongoing review of these core skills so your child fully grasps them by the end of the year. (Educators call this a *spiral approach* to review, because children periodically revisit topics, just as the curve of a spiral returns to the same point on a circle.)

Positive Attitude

The lessons in *Sixth Grade Math with Confidence* include games, hands-on learning, and lots of real-life applications so your child enjoys and even looks forward to math time. Optional enrichment lessons at the end of each unit provide a break from the usual routine and help your child appreciate how math is used in real life.

Overview

You'll need three books to teach *Sixth Grade Math with Confidence*. All three books are essential for the program.

- This Instructor Guide contains the scripted lesson plans for the entire year.
- Workbook Part A contains the workbook pages for the first half of the year (Units 1-8).
- Workbook Part B contains the workbook pages for the second half of the year (Units 9-16).

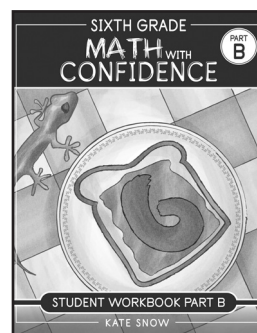
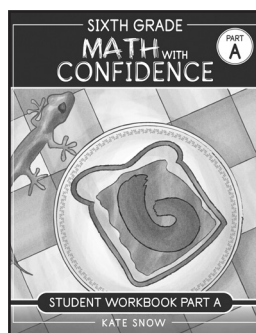
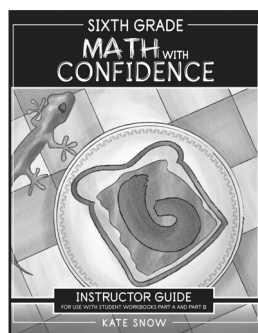

Units

Sixth Grade Math with Confidence is organized into 16 units. Each unit focuses on developing thorough understanding of one main concept, such as ratios, percentages, or equations. Units vary in length from 6 to 13 lessons, and there are a total of 139 lessons. The final lesson in each unit is an optional enrichment lesson.

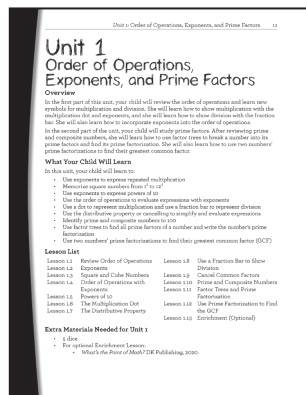

The preview for each unit includes the following:

- **Overview.** A brief summary of what you'll teach your child.
- **What Your Child Will Learn.** A detailed list of objectives for the unit.
- **Lesson List.** The full list of lessons included in the unit.
- **Extra Materials.** This section gives you a heads-up if you need any extra materials for the unit. You'll sometimes need to supplement your regular math materials with a few everyday household items, such as tape or scissors. The optional enrichment lessons also sometimes require extra materials.
- **Teaching Math with Confidence.** These notes help you understand more deeply how children learn math so that you're well-prepared to teach the new concepts.

Lessons

You'll need both the Instructor Guide and Student Workbook for every lesson. Expect your child to spend an average of 30-45 minutes on each lesson, with 10-15 minutes of parent-led instruction and 20-30 minutes of independent work. However, this will vary depending on your teaching style and your child's learning style—and whether you have any younger children interrupting you!

The Instructor Guide contains the scripted, open-and-go lesson plans. Within the Instructor Guide:

- **Bold text** indicates what you are to say.
- *Italic text* provides sample answers.
- **Gray-highlighted text** indicates explanatory notes.

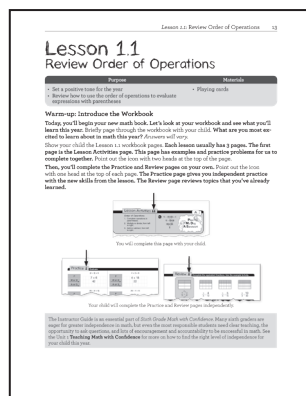

The Student Workbook includes three workbook pages for each lesson. First, you'll use the Lesson Activities page to teach your child the new concept or skill. Then, your child will complete the Practice and Review pages to reinforce what she learned in the lesson and review previously learned skills.

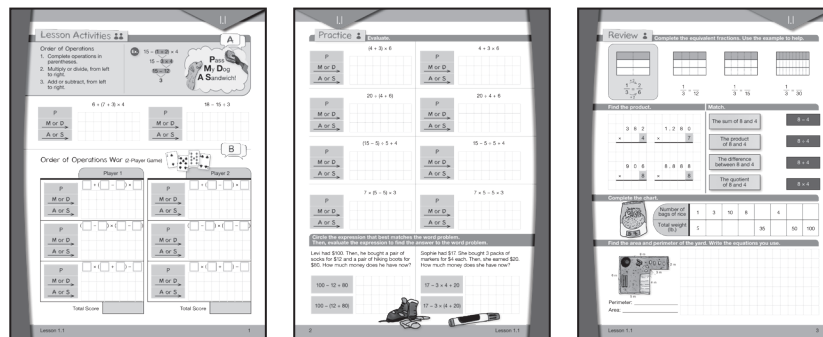

Memory work and warm-up activity with parent

Each lesson begins with a few memory work review questions and a quick warm-up activity. The memory work questions are listed at the top of each lesson. Reviewing a few questions daily helps your child master these important facts and vocabulary words. The warm-up activity eases your child into math time and helps start the lesson on a confident and positive note.

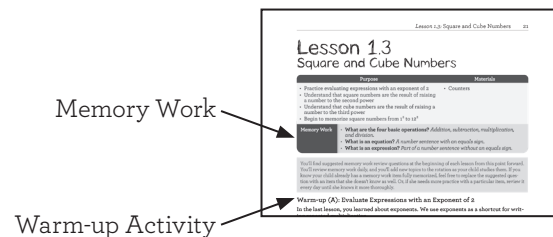

Lesson activities with parent

Next, you'll use the scripted lesson plan and Lesson Activities page to teach your child new concepts and skills. The Instructor Guide and Lesson Activities workbook pages are lettered so that it's easy to see how they align. Some activities are only in the Instructor Guide, without a matching section on the Lesson Activities page.

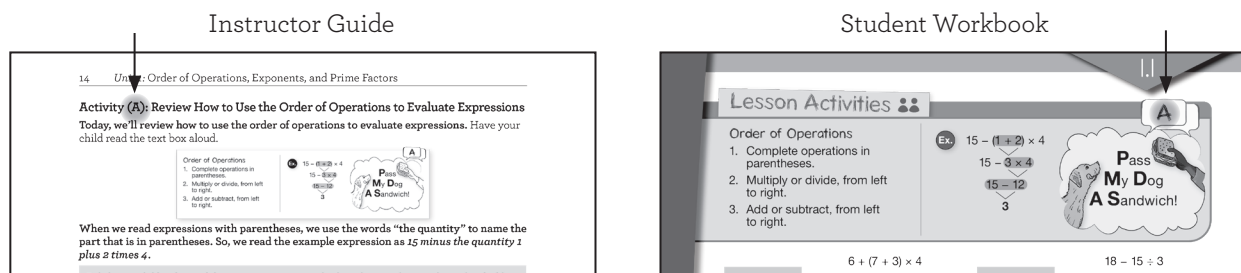

The activity headings and images in the Instructor Guide are lettered to help you find the matching activity in the Student Workbook.

Instructor Guide

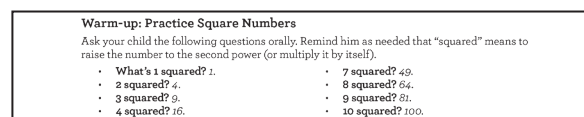

Some activity headings in the Instructor Guide do not have a letter. These activities do not have a matching section in the Student Workbook, and they are completed either orally or with hands-on materials instead.

As in the previous levels of *Math with Confidence*, the **lesson plans in the Instructor Guide are an essential part of the program**. Even if you don't follow the scripted lesson word-for-word, make sure you use this Instructor Guide alongside the Student Workbook. The text on the Lesson Activities page summarizes the core concept or skill in each lesson, but there are often warm-ups, games, and explanations in the Instructor Guide that aren't printed in the workbook.

Independent practice

Last, your child will complete the Practice and Review workbook pages on her own. You'll find answer keys for the Practice and Review pages at the end of each unit.

Enrichment Lessons (Optional)

Optional enrichment lessons are scheduled at the end of each unit. The Instructor Guide provides enrichment activity directions, while the Student Workbook includes a two-page Unit Wrap-Up for your child to complete.

Many parents and children find that the enrichment lessons are their favorite part of the program. (Siblings often enjoy participating in them, too!) However, these lessons are completely optional. You are free to choose the ones that sound the most fun for your family, or skip them entirely if your schedule is too full.

Math enrichment book

Each enrichment lesson lists suggested pages to read from *What's the Point of Math?* from DK Publishing. This book makes a fun companion to *Sixth Grade Math with Confidence*. It includes many real-life examples of the topics your child will study this year, including prime numbers, data and statistics, and geometry.

Enrichment activity

The enrichment activities help your child understand and appreciate how math is used in everyday life. You'll find suggestions for real-world applications to make math come alive for your child.

Unit Wrap-up (review and assessment)

The Unit Wrap-Ups provide two pages of additional exercises for the concepts and skills your child learned in the unit. You can use them to casually review the unit, or you can use them as tests to assess your child's progress more formally. Either way, children and parents often find it very satisfying to see this concrete evidence of growth. If you live in a state where you're required to provide evidence of learning, you may want to save them for your child's portfolio.

The image shows two pages from a Unit Wrap-Up for Lesson 1.13. The left page is titled 'Unit Wrap-Up 4' and includes a 'Match' section with powers of 4 (4 cubed, 4 squared, 4 to the power of 5, 4 to the first power) and a table for powers of 5. The right page is titled 'Unit Wrap-Up 5' and includes a 'Prime Factorizations' section with a grid of numbers and a tree diagram for 100.

Your child is not expected to fully master every skill from every unit before moving on to the next unit. See below for more on pacing and assessing your child's progress.

Pacing and Checkpoints

Sixth Grade Math with Confidence provides lots of flexibility so your child can learn at his own pace. You know your child best, and you are always welcome to slow down or speed up the pace of the lessons based on your child's needs.

Is My Child Ready to Start *Sixth Grade Math with Confidence*?

Your child is ready to begin this program if he can:

- Solve whole-number multiplication and division problems (up to three digits times two digits or four digits divided by two digits).
- Find a fraction of a set or measurement.
- Add and subtract fractions or mixed numbers with different denominators.
- Multiply fractions and mixed numbers.
- Read, write, compare, and order decimals to the thousandths-place.
- Add and subtract decimals to the thousandths-place.
- Multiply and divide decimals by whole numbers.
- Find the volume of a rectangular prism.
- Find the mean and median for a small data set.

All of these skills are reviewed in the first few units, so don't worry if your child needs a refresher on a few of them. However, if your child is shaky on many of these skills, *Fifth Grade Math with Confidence* may be a better fit for him. Math skills build incrementally, and it will be difficult for your child to develop proficiency and confidence with the new sixth-grade skills if he has a weak foundation.

How Do I Know Whether to Stick with a Lesson (or Unit) or Move On?

Most children need lots of exposure to a new concept or skill before they fully grasp it. Each lesson in *Sixth Grade Math with Confidence* gently builds on the previous one, but your child doesn't need to completely master every lesson before moving on to the next. The program includes many opportunities for practice and review before your child is expected to achieve full proficiency with a topic.

In general, continue teaching new lessons until you reach the end of a unit. At the end of each unit, you'll find a Checkpoint that provides guidance on whether your child is ready to move on to the next unit.

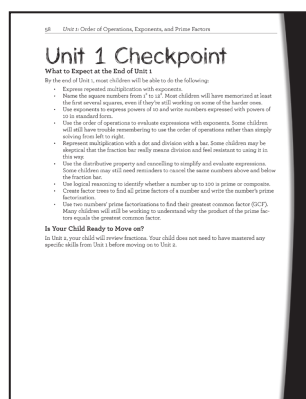

The Checkpoints are divided into three parts:

- **What to Expect at the End of the Unit** This list of skills tells you what sixth graders typically are able to do at the end of each unit.
- **Is Your Child Ready to Move On?** This section tells you what your child needs to have mastered before moving on to the next unit.
- **What to Do if Your Child Needs More Practice** If your child isn't quite ready to move on, this section gives you options for reviewing and practicing the skills your child needs to master before the next unit. (This section is omitted if no specific skills are necessary for the next unit.)

Scheduling

Sixth Grade Math with Confidence includes 139 lessons. 123 are regular lessons, and 16 are optional enrichment lessons. You're welcome to adjust the number of lessons you teach per week to best fit your family's schedule. Some families prefer to teach math 5 days per week, while others prefer to teach math 4 days per week and leave one day open for co-ops, errands, or field trips.

Use the following guidelines to plan your year:

- If you teach 4 lessons per week and teach all the enrichment lessons, *Sixth Grade Math with Confidence* will take you 35 weeks.
- If you teach 4 lessons per week and skip the enrichment lessons, *Sixth Grade Math with Confidence* will take you 31 weeks.
- If you teach 5 lessons per week and teach all the enrichment lessons, *Sixth Grade Math with Confidence* will take you 28 weeks.
- If you teach 5 lessons per week and skip the enrichment lessons, *Sixth Grade Math with Confidence* will take you 25 weeks.

Use this list as a rough guide to planning your year, but don't set it in stone. You'll generally be able to cover one lesson per day, but you may occasionally find that you want to split a lesson over two days.

How Can I Adjust the Lessons to Best Fit My Child and My Schedule?

Children vary tremendously in how quickly they learn new math concepts and skills. Use these suggestions to adjust the lessons to best fit your child's needs and your family's schedule.

- If your student is a fast processor or picks up math skills quickly, you may be able to condense lessons and teach more than one lesson in one day. If so, teach the concepts that are new to your child. Then, have your child complete a selection of exercises on the corresponding Practice and Review pages.
- If your child has a slower processing speed or takes a while to grasp math concepts and skills, some lessons may take longer than you would like (or longer than your child is able to stay engaged and attentive). If that's the case, set a timer for your desired lesson length, stop when the timer goes off, and continue the next day where you left off. In the elementary years, you are setting a foundation for a lifetime of proficiency and confidence in math. It's okay not to rush through these essential skills.
- If your child doesn't have the stamina to complete the Practice and Review pages at the same time, split the lesson into two parts. Do the Lesson Activities page and Practice page during one part of the day, and then have your child complete the Review page at a different time of the day.

- Games provide a fun way to practice math skills, and they can be a great way to bond with your child. However, if your child doesn't enjoy games, or you don't have time for a game on a particular day, choose a few problems from the game for your child to solve instead. That way, he'll still get the extra practice that the game was meant to provide.
- Don't worry if you have a bad day every once in a while. Extra tiredness, oncoming illness, or just plain grumpiness can make for a less-than-cheerful math lesson. It's perfectly normal for children to occasionally get frustrated, and it doesn't mean that you're a bad math teacher or need to change the way you teach. If emotions rise during math, just cut the lesson short and resume later in the day or the next day. Most of the time, you'll find that the next day goes much better.

What You'll Need

If you've used previous levels of *Math with Confidence*, you'll find that sixth grade has fewer manipulatives and Blackline Masters to manage. Most lessons only require materials from your Math Kit, but you'll also occasionally use everyday objects to enhance the lessons.

How to Create Your Math Kit

You'll use materials from your Math Kit in most core lessons. Stick the following materials in a box or basket so they're always ready to go, and keep them handy when you're teaching.

- **30 small counters (15 each of 2 different colors).** Any type of small object (such as plastic tiles, Legos, blocks, or plastic discs) is fine. You will mostly use these for game pieces.
- **Two packs of playing cards and two dice.** You'll use playing cards and dice for some of the games in this book. Any standard 52-card decks and regular, six-sided dice will work fine.
- **1-foot (or 30-centimeter) ruler.**
- **Highlighter.** Any color is fine.
- **Scrap paper.** Your child may occasionally need scrap paper for extra space for solving problems. Any kind of paper is fine, including plain copy paper or lined notebook paper.
- **Pencils.** Keep sharp pencils on hand for lessons and workbook pages.



You will occasionally need to save items for future lessons. This symbol will alert you if you need to save anything.

Other Supplies Needed

You'll only need your Math Kit for most lessons, but occasionally you'll need a few other common household items. You'll find these items listed in three different places in the curriculum to make sure you always know what you need:

- The preview for each unit lists all extra household items needed.
- The top of each lesson lists all supplies you'll need to teach that lesson. These lists include items from your Math Kit as well as extra household items. (Note that some lessons require scrap paper or a highlighter. To save space, these items are not listed separately in the materials list.)
- You'll find the complete list of household items needed throughout the year on pages 516-517.

Don't feel you have to gather the extra household items now. Most are common things like tape or scissors that you can grab right before you begin the lesson.

Helpful Resources

You'll find an appendix of helpful resources at the back of this book:

- Memory Work
- Scope and Sequence
- Materials List
- Blackline Masters

Unit 1

Order of Operations, Exponents, and Prime Factors

Overview

In the first part of this unit, your child will review the order of operations and learn new symbols for multiplication and division. She will learn how to show multiplication with the multiplication dot and exponents, and she will learn how to show division with the fraction bar. She will also learn how to incorporate exponents into the order of operations.

In the second part of the unit, your child will study prime factors. After reviewing prime and composite numbers, she will learn how to use factor trees to break a number into its prime factors and find its prime factorization. She will also learn how to use two numbers' prime factorizations to find their greatest common factor.

What Your Child Will Learn

In this unit, your child will learn to:

- Use exponents to express repeated multiplication
- Memorize square numbers from 1^2 to 12^2
- Use exponents to express powers of 10
- Use the order of operations to evaluate expressions with exponents
- Use a dot to represent multiplication and use a fraction bar to represent division
- Use the distributive property or cancelling to simplify and evaluate expressions
- Identify prime and composite numbers to 100
- Use factor trees to find all prime factors of a number and write the number's prime factorization
- Use two numbers' prime factorizations to find their greatest common factor (GCF)

Lesson List

Lesson 1.1	Review Order of Operations	Lesson 1.8	Use a Fraction Bar to Show Division
Lesson 1.2	Exponents	Lesson 1.9	Cancel Common Factors
Lesson 1.3	Square and Cube Numbers	Lesson 1.10	Prime and Composite Numbers
Lesson 1.4	Order of Operations with Exponents	Lesson 1.11	Factor Trees and Prime Factorization
Lesson 1.5	Powers of 10	Lesson 1.12	Use Prime Factorization to Find the GCF
Lesson 1.6	The Multiplication Dot	Lesson 1.13	Enrichment (Optional)
Lesson 1.7	The Distributive Property		

Extra Materials Needed for Unit 1

- 5 dice
- For optional Enrichment Lesson:
 - × *What's the Point of Math?* DK Publishing, 2020.

Teaching Math with Confidence: Don't Just Hand Your Child the Workbook!

Many sixth graders are eager for more independence. As a result, it may be tempting to simply hand your child the workbook and encourage her to learn math on her own this year. But before you do that, think back to your own sixth grade math education. Were you ready to study and learn math independently, without a teacher? Probably not! Even the most responsible middle-school and high-school students need clear teaching, the opportunity to ask questions, and lots of encouragement and accountability to be successful in math.

As in the previous levels of *Math with Confidence*, the Student Workbook is not designed to be used on its own. The text on the Lesson Activities page summarizes the core concept or skill in each lesson, but there are often warm-ups, games, and explanations in the Instructor Guide that aren't printed in the workbook.

Plus, when children study math on their own, they often rush and learn just enough to complete the practice exercises. They miss out on the chance to develop deeper conceptual understanding, and they don't take the time to think about how the new material connects to previously learned skills. Math is ruthlessly sequential, so this shallow learning often leads to frustration and struggle later when the child must tackle more challenging concepts.

Instead of simply handing your child the workbook, aim to provide a high level of support and accountability as your child gradually takes more responsibility for her learning over the next few years. Here are a few options to try as you seek a healthy level of independence for your student:

- Have your child read the text and complete the practice problems on the Lesson Activities page on her own. Then, ask her to “**be the teacher**” and explain how she solved one or two of the problems. Use the Instructor Guide to highlight any additional teaching points that she misses.
- **Ask lots of questions** to check that your child understands the new material. The Instructor Guide often includes questions for checking understanding, or you can make up a few of your own.
- If your child doesn't understand a new concept but resists listening to you explain it, come alongside her as a **coach** and work to understand the text and examples together.
- **If your child doesn't enjoy playing games** (or finds them babyish), have her solve a few problems like the ones in the game instead. Use these problems to check that she understands how to apply the new skill.
- If your child has trouble completing the Practice page, encourage her to **look back at the Lesson Activities page**. If she's still stuck, have her write a question mark next to the problem rather than immediately interrupting you. Discuss these problems after she has finished the rest of the page. Children often discover that they know how to find the answer if they wait a few minutes before asking for help.
- Provide accountability by **checking your student's work promptly**. (It's ideal if you can correct her work immediately after she finishes.) Have her fix any mistakes so that she has good incentive to always put forth her best effort.
- Show your child the **Unit Reference pages** at the back of the Student Workbooks. These pages provide a summary of the key teachings in each unit so that your child can refer to them rather than asking you for help. Encourage your child to refer to these pages if she can't remember how to solve a problem on a Review page.
- Some sixth graders want their parent right by their side and do not want to be more independent in math. **Don't push more independence than your child is ready for**. You know your child best, and it's fine for you to support and encourage your child as much as she needs.

Lesson 1.2

Exponents

Purpose	Materials
<ul style="list-style-type: none"> • Introduce memory work • Write repeated multiplication expressions with exponents and vice versa 	<ul style="list-style-type: none"> • Memory Work (Blackline Master 1) • Die • Counters

In this lesson, you'll introduce your child to the Memory Work list (Blackline Master 1). Many families find it helpful to post the Memory Work pages near their lesson area to help their children gradually memorize the items over the course of the year.

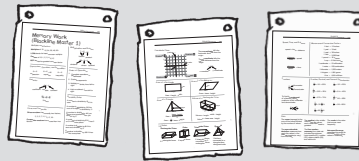

All Blackline Masters are available at the back of the book. **You can also find all Blackline Masters at welltrainedmind.com/mwc for easy printing.**

Warm-up: Introduce Memory Work

Show your child the Memory Work list (Blackline Master 1). **You'll memorize these important vocabulary words and facts this year. You already know many of them, and some of them are new. We'll practice them throughout the year so that you learn all of them.** Briefly look over the list with your child and have him point out a few facts he already knows.

Children learned many of these items in *Fifth Grade Math with Confidence*. If you didn't use *Fifth Grade Math with Confidence*, you do not need to stop and help your child memorize all these items now. He'll have plenty of opportunities to learn them throughout sixth grade.

Activity (A): Explore Repeated Multiplication

When you were younger, you learned that multiplication is a shortcut for writing repeated addition. Today, you'll learn a shortcut for repeated multiplication. Have your child complete the exercises.

$1 \times 1 \times 1 \times 1 \times 1 = \underline{1}$
 $2 \times 2 \times 2 \times 2 = \underline{16}$
 $3 \times 3 \times 3 = \underline{27}$

Activity (B): Introduce Exponents

You'll find text and example problems on the Lesson Activities pages again this year. We'll read the text and study the examples together, so that you gradually learn how to study math more independently.

Remember, reading math is very different from reading a story. When you read a story, you can enjoy the story even if you don't fully understand every word or detail. But when you read math, it's important to understand the meaning of every word and detail. Have your child read the text box aloud.

Exponents
Exponents are a shortcut for writing repeated multiplication. The base is the number you multiply. The exponent tells how many times the base is multiplied.

base exponent

$4^3 = 4 \times 4 \times 4 = 64$

We read 4^3 as "4 to the third power" or "4 to the power of 3."

B

Ex. $2^5 = 2 \times 2 \times 2 \times 2 \times 2 = 32$

Ex. $7^2 = 7 \times 7 = 49$

Ex. $3^0 = 1$
Any number to the power of 0 is 1.

If this text (or any of the text in the book) is above your child's reading level, read it aloud to him instead.

Children sometimes assume they can grasp the examples at a glance and want to rush past them. If this becomes a source of conflict with your child, write out the example step-by-step on a separate piece of paper or on a whiteboard. Or, cover the example with a piece of paper and reveal only one line at a time. It may also help to cover the rest of the page with a piece of paper to help focus your child's attention on the example you're discussing.

Let's study the examples to learn how to use exponents. Read aloud the first example: **2 to the fifth power.**

- What number is the base in this problem? 2.
- What number is the exponent? 5.
- 2 to the fifth power means 2 multiplied by itself 5 times, so the matching multiplication problem is 2 times 2 times 2 times 2 times 2.
- What's 2 times 2? 4. Times 2? 8. Times 2? 16. Times 2? 32. So, 2 to the fifth power equals 32.

Read aloud the second example: **7 to the second power.**

- What number is the base in this problem? 7.
- What number is the exponent? 2.
- 7 to the second power means 7 times 7. What's 7 times 7? 49. So, 7 to the second power is 49.

Your child will learn to read 7^2 as "7 squared" in the next lesson.

Read aloud the third example: **3 to the power of zero.**

- What number is the base in this problem? 3.
- What number is the exponent? 0.
- 3 to the power of zero means "3 times itself 0 times."
- Mathematicians have decided that any number to the power of zero equals 1. So, 3 to the power of zero equals 1.

If your child wonders why any number to the zero power equals 1, explain that we can also understand exponents as telling how many times to multiply 1 by the base. For example, we can think of 2^5 as multiplying 1 by 2 five times:

$$2^5 = 1 \times 2 \times 2 \times 2 \times 2 \times 2$$

In the same way, we can think of 3^0 as multiplying 1 by 3 zero times:

$$3^0 = 1$$

If this explanation doesn't resonate with your child, use the following pattern to demonstrate why this rule is necessary. **As we go down the rows, the exponent decreases by 1 and the value of the expression is divided by 3. So, when we decrease the exponent from 1 to 0, we divide 3 by 3 to see that the value of 3^0 is 1.**

$$\begin{array}{r} 3^3 = 3 \times 3 \times 3 = 27 \\ \quad \quad \quad \downarrow \div 3 \\ 3^2 = 3 \times 3 = 9 \\ \quad \quad \quad \downarrow \div 3 \\ 3^1 = 3 = 3 \\ \quad \quad \quad \downarrow \div 3 \\ 3^0 = 1 \end{array}$$

Have your child read each practice problem aloud. Then, have him write out and solve the matching multiplication problem.

$3^4 = \underline{\quad 81 \quad}$	$10^3 = \underline{\quad 1,000 \quad}$	$36^0 = \underline{\quad 1 \quad}$ B
$3 \times 3 \times 3 \times 3 = 81$	$10 \times 10 \times 10 = 1,000$	

Activity (C): Play Exponent Three in a Row

Play Exponent Three in a Row.

Exponent Three in a Row

Materials: Die, counters of two colors

Object of the Game: Be the first player to place 3 counters in a row (horizontally, vertically, or diagonally) in the circles in the center of the game board.

Have each player choose a different-colored counter to use as a game token and place it on one of the Start squares.

On your turn, roll the die and advance your token the corresponding number of squares clockwise around the path. When you land on a square, find the matching expression in the middle of the game board. Place a counter on the matching expression and tell its value. For example, if you land on 4×4 , place a counter on 4^2 and say 16.

If there is already a counter on the matching circle, play passes to the other player. If you land on one of the Start squares, roll again.

Play until one player covers 3 circles in a row, either horizontally, vertically, or diagonally.

Crash variation: If you land on an expression and your opponent already has a counter on the matching circle, “crash” into your opponent’s counter and replace it with one of your own. This variation works best if you own transparent counters, so it’s easy to see the numbers under the counters.

Directions continued on next page.

Answer Key:

$10 \times 10 = 10^2 = 100$

$0 \times 0 \times 0 = 0^3 = 0$

$6 \times 6 = 6^2 = 36$

$5 \times 5 \times 5 = 5^3 = 125$

$2 = 2^1 = 2$

$4 \times 4 = 4^2 = 16$

$2 \times 2 \times 2 = 2^3 = 8$

$10 \times 10 \times 10 = 10^3 = 1,000$

$3 \times 3 \times 3 = 3^3 = 27$

$1 \times 1 \times 1 \times 1 = 1^4 = 1$

$4 = 4^1 = 4$

$3 \times 3 = 3^2 = 9$

$5 \times 5 = 5^2 = 25$

$2 \times 2 = 2^2 = 4$

$7 \times 7 = 7^2 = 49$

$2 \times 2 \times 2 \times 2 = 2^4 = 16$

Independent Practice and Review

Have your child complete the Lesson 1.2 Practice and Review workbook pages.

The workbook pages occasionally include optional starred problems. These problems provide extra challenge and give your child the chance to stretch his skills. If your child struggles with the challenge problems or feels frustrated by them, feel free to skip them.

Lesson 3.3

Find the Area of a Parallelogram

Purpose	Materials
<ul style="list-style-type: none"> Review properties of parallelograms Find the area of parallelograms Understand how the formula for the area of a parallelogram is related to the formula for the area of a rectangle 	<ul style="list-style-type: none"> Paper shape A from Blackline Master 2 Ruler Scissors
Memory Work	<ul style="list-style-type: none"> How many inches equal 1 foot? 12. How many feet equal 1 yard? 3. How many inches equal 1 yard? 36. How many feet equal 1 mile? 5,280. How many ounces equal 1 pound? 16. How many fluid ounces equal 1 cup? 8.

In this lesson, your child will learn how the formula for the area of a parallelogram is derived from the formula for the area of a rectangle. Make sure to use paper parallelogram A from Blackline Master 2 to give your child a concrete understanding of the formula. See the Unit 3 **Teaching Math with Confidence** for more on the relationship between the formulas.

Warm-up: Review Properties of Parallelograms

Today, you'll learn how to find the area of a parallelogram. We'll warm up by reviewing the properties of parallelograms.

Show your child paper parallelogram A from Blackline Master 2. **Parallelograms have 2 pairs of parallel sides. Parallel sides are always the same distance away from each other, like railroad tracks.**

- Point to the bottom side of the parallelogram. **Which side is parallel to this side?** *Child points to the top side. The bottom and top sides of the parallelogram are parallel to each other. Both sides have the same length.*
- Point to the left side of the parallelogram. **Which side is parallel to this side?** *Child points to the right side. The left and right sides of the parallelogram are parallel to each other. Both sides have the same length.*

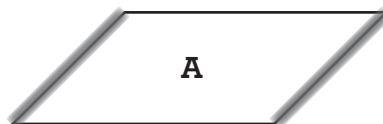

The opposite sides of a parallelogram are parallel to each other and have the same length.

Each small box in this paper parallelogram is 1 centimeter long and 1 centimeter wide.

- We call the bottom side of a parallelogram its **base**. Have your child use a ruler (or count boxes) to find the length of the base. **How long is this parallelogram's base? 7 centimeters.**
- The parallelogram's **height** is how tall it is when it's sitting on its base. Hold the paper parallelogram as shown, so that it stands on the table on one of its long sides. Have your child use a ruler (or count boxes) to find the height of the parallelogram. **What is the height of the parallelogram? 3 centimeters.**

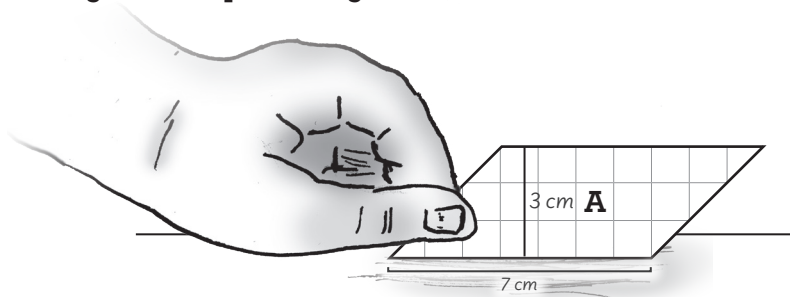

What does it mean if two lines are perpendicular? *The lines meet to form a right angle. The base and height of a parallelogram are always perpendicular to each other.*

Explain as needed that “base” and “height” can refer to the lines themselves as well as the length of the lines.

Place the parallelogram flat on the table and point to the right side. **Do you think this side is longer than, shorter than, or equal to the height?** *Answers will vary.* Have your child use a ruler to measure the side in centimeters. **How long is the side?** *About 4 centimeters.* **When we stand a parallelogram on its base, the slanted sides are always longer than the parallelogram's height.**

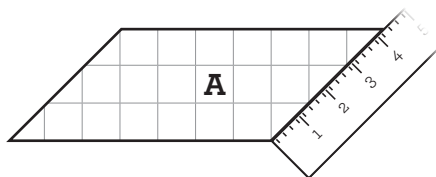

Activity (A): Use a Formula to Find the Area of a Parallelogram

In Lesson 3.1, we reviewed the formula for the area of a rectangle. **What is the formula for the area of a rectangle?** *Length times width.* **Knowing how to find the area of a rectangle helps us find the area of a parallelogram.** Have your child read the text box aloud.

Area of a Parallelogram

Any parallelogram can be transformed into a rectangle.
Just cut off the right triangle at one end and move it to the other end!
You create a rectangle with the same base and height as the parallelogram.
To find the area of a parallelogram, multiply the base by the height.

Area = base · height
 $A = b \cdot h$

Ex. What is the area of this parallelogram?

$A = 7 \text{ cm} \cdot 3 \text{ cm}$
 $A = 21 \text{ cm}^2$

Remind your child as needed that a right triangle is a triangle with one right angle.

Let's use our paper parallelogram to understand this formula. Cut a right triangle off the left edge of the paper parallelogram and move it as shown. **What's the area of this rectangle?** 21 square centimeters. **How do you know?** Sample answer: 7 times 3 equals 21.

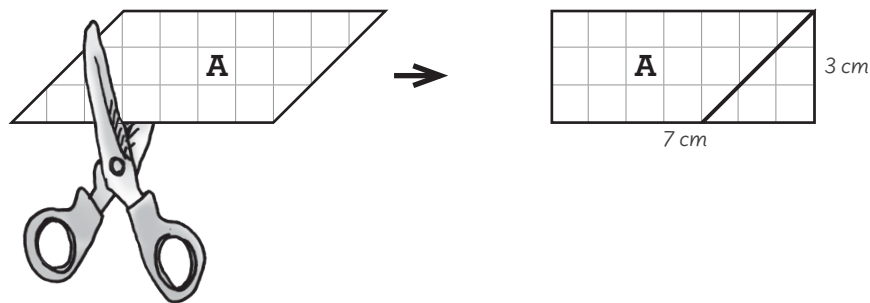

The area of this rectangle is 21 square centimeters. The parallelogram covers the same amount of space as the rectangle. So, to find the area of a parallelogram, we find the area of the matching rectangle and multiply its base by its height.

Remember, we found in the warm-up that the slanted side is longer than the height. When you find the area of a parallelogram, don't multiply the base by the length of the other side. Instead, make sure you multiply the base by the *height*.

Activity (B): Practice Identifying Bases and Heights in Parallelograms

In the next activity, we'll find the area of parallelograms on a grid. When shapes are printed on a grid, we can use the grid lines to measure the base and height.

Point to the top left parallelogram on the game board. The bottom side of this parallelogram is aligned with the grid, so we know how many units long it is. We'll use it as the base. Highlight the bottom side as shown. Then, we look for a grid line perpendicular to the base to measure the height. Highlight the height as shown.

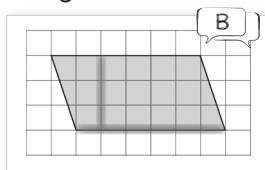

Point to the parallelogram in the middle of the bottom row. Point to its bottom side. This side isn't aligned with the grid. If we choose this side to be the base, we don't know how many units long it is.

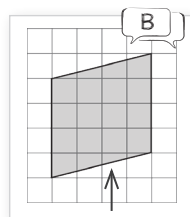

Instead, we need to pick a side aligned with the grid to be the base. For this parallelogram, both the left and right sides are aligned with the grid, so we could use either side as the base. Highlight the left side. Then, we use a grid line perpendicular to the base to find the height. Highlight the height as shown.

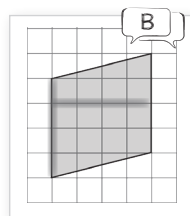

If your child is confused by this idea, rotate the paper 90° so that the base is at the bottom of the parallelogram. **It's okay for the base not to be the bottom side of the shape, as long as we measure the height perpendicular to the base.**

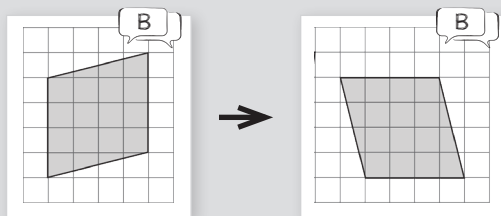

Activity (B): Play Parallelogram Pick

Play Parallelogram Pick.

Parallelogram Pick

Materials: None

Object of the Game: Win the most points by choosing parallelograms with a greater area than your opponent's.

On your turn, choose a parallelogram on the game board and write your initials next to the parallelogram. Highlight the base and height of the parallelogram and label their lengths. Then, multiply the base by the height to find the area. Write the area inside the parallelogram and circle it. You win this number of points.

For example, if you choose the top left parallelogram: **This parallelogram's base is 6 units long. Its height is 3 units. 6 times 3 is 18, so the area is 18 square units.**

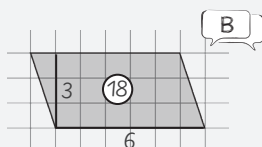

Sample play. This player earns 18 points, since the parallelogram has an area of 18 square units.

Take turns until each player has found the area of 4 parallelograms. Each player adds up their points. Whoever has the greater total number of points wins.

Answer Key:

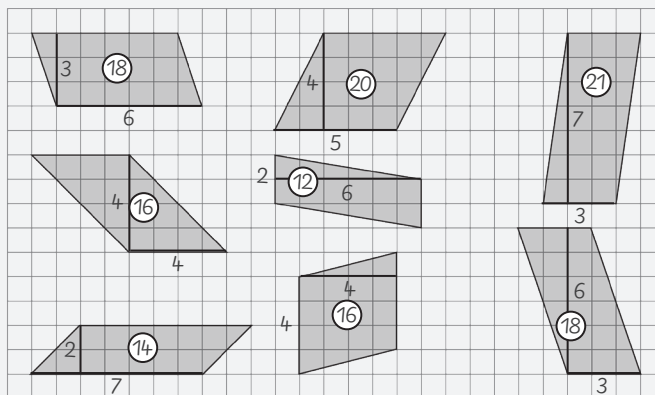

Independent Practice and Review

Have your child complete the Lesson 3.3 Practice and Review workbook pages.

Lesson 4.3

Equivalent Ratios

Purpose	Materials
<ul style="list-style-type: none"> Use a ratio to find proportional combinations of ingredients Introduce ratio tables Use ratio tables to simplify ratios Understand that ratios with the same simplest form are equivalent to each other 	<ul style="list-style-type: none"> None
Memory Work	<ul style="list-style-type: none"> What does LCM stand for? <i>Least common multiple.</i> What does GCF stand for? <i>Greatest common factor.</i>

In this lesson, you'll introduce your child to ratio tables. These simple charts are very helpful in solving ratio problems, and your child will use them throughout the rest of the unit. See the Unit 4 **Teaching Math with Confidence** for more on ratio tables.

Warm-up (A): Complete a Salad Dressing Ingredient Chart

In the last two lessons, you learned about ratios. We often use ratios in cooking. This salad dressing recipe calls for 1 part vinegar to 3 parts olive oil. That means that you should combine vinegar and olive oil in a 1 to 3 ratio. You can use any amount of vinegar you want, as long as you use 3 times as much olive oil as vinegar.

If you use 1 tablespoon of vinegar, you use 3 tablespoons of olive oil. If you use 2 tablespoons of vinegar, how many tablespoons of olive oil should you use? 6. How do you know? *Sample answers: 2 times 3 equals 6. I doubled the amount you need for 1 tablespoon of vinegar. I added 3 more tablespoons of olive oil.* Have your child complete the rest of the chart in the same way.

Salad Dressing - 1 part vinegar - 3 parts olive oil	Vinegar (Tablespoons)	1	2	3	4	5	6
	Olive oil (Tablespoons)	3	6	9	12	15	18

What relationships do you notice in the chart? *Sample answers: The amount of vinegar goes up by 1 tablespoon and the amount of olive oil goes up by 3 tablespoons. The amount of vinegar is always one-third of the amount of olive oil.*

All the combinations have the same ratio of vinegar to olive oil. We say that they all have the same proportion of vinegar and olive oil. They would all taste the same, no matter which combination from the chart you used.

Activity (B): Use Ratio Tables to Find Equivalent Ratios

In the last lesson, you learned how to simplify ratios. Today, you'll learn how to use a ratio table to simplify ratios and tell whether they are equivalent to each other.

Ratio tables are a lot like the chart you completed in part A. We use them to find combinations that have the same ratio, just like the oil and vinegar in the salad dressing chart. Have your child read the text box aloud.

B

Use Ratio Tables to Find Equivalent Ratios

Ratios that have the same simplest form are equivalent to each other. To check whether two ratios are equivalent to each other, write each ratio in simplest form.

We can use ratio tables to organize the information in ratio problems. Make sure you write each number in the matching row.

Ex. Audrey used 30 mL of vinegar and 120 mL of olive oil. Jonathan used 25 mL of vinegar and 75 mL of olive oil. Who followed the salad dressing recipe (from part A) correctly?

Audrey			
Vinegar	30	1	
Olive oil	120	4	

Jonathan			
Vinegar	25	1	
Olive oil	75	3	

Jonathan's ratio simplifies to 1:3, so he followed the recipe correctly.

Use the following questions to discuss the example:

- **Audrey used 30 milliliters of vinegar and 120 milliliters of olive oil.**
- **30 and 120 are both divisible by 30, so we divide by 30 to find the simplest form of the ratio. What's the simplest form of Audrey's ratio? 1 to 4.**
- **Does Audrey's ratio match the recipe in part A? No.**
- **Jonathan used 25 milliliters of vinegar and 75 milliliters of olive oil.**
- **25 and 75 are both divisible by 25, so we divide by 25 to find the simplest form of the ratio. What's the simplest form of Jonathan's ratio? 1 to 3.**
- **Does Jonathan's ratio match the recipe in part A? Yes.**
- **Whose salad dressing would taste more strongly of vinegar? Jonathan's. How do you know? Sample answer: His recipe uses less olive oil to dilute the vinegar.**

How is this process like simplifying a fraction? Sample answer: You divide both numbers by the same number.

These ratios aren't fractions. But, you can use what you know about simplifying fractions to help you simplify the ratios. If you wrote the numbers from each column in the chart as a fraction, the fractions would be equivalent to each other.

$$\begin{array}{c|c|c} \text{Vinegar} & 30 & 1 \\ \hline \text{Olive oil} & 120 & 4 \end{array} \quad \frac{30}{120} = \frac{1}{4} \qquad \begin{array}{c|c|c} \text{Vinegar} & 25 & 1 \\ \hline \text{Olive oil} & 75 & 3 \end{array} \quad \frac{25}{75} = \frac{1}{3}$$

In a fraction, the numerator represents part of a whole amount, while the denominator tells how many parts the whole was split into. These ratios tell the relationship between the ingredients (rather than comparing each ingredient to the total amount of dressing), so they aren't fractions. Your child will learn more about the relationship between ratios and fractions in Lessons 4.6 and 4.8.

Activity (C): Use Ratio Tables to Simplify Student-Instructor Ratios

This chart shows the number of students and instructors in some enrichment classes. Which of these classes would you most like to take? Answers will vary.

In some of these classes, each instructor has a lot of students to teach. In others, each instructor has only a few students to teach. Have your child simplify the ratio of students to instructors in each class and write the simplified ratio in the ratio table. Then, have your child answer the questions.

C

★ Join Us for Enrichment Classes at the Community Center! ★

Woodworking for Beginners	Introduction to Pickleball	Soccer Skills ★
Students 18 9	Students 40 20	Students 32 8
Instructors 4 2	Instructors 2 1	Instructors 4 1
Advanced Jazz Band	Beginning Oil Painting	Recreational Scuba Diving
Students 60 20	Students 16 8	Students 6 3
Instructors 3 1	Instructors 2 1	Instructors 4 2

Which class has the same student-instructor ratio as Soccer Skills?

Beginning Oil Painting

Which class has the same student-instructor ratio as Introduction to Pickleball?

Advanced Jazz Band

Which class has the most personal attention for each student?

Recreational Scuba Diving

Use the following questions to discuss the ratios' real-life meanings.

- **Which two classes have the most students per instructor?** *Introduction to Pickleball and Advanced Jazz Band. Both classes have 20 students for each instructor.*
- **Which class has the fewest students per instructor?** *Scuba Diving. The scuba diving class has 3 students for every 2 instructors. That means that each instructor only has to teach 1 or 2 students.*
- **Why do you think the scuba diving class has a lower student-to-instructor ratio than pickleball or jazz band?** *Sample answer: It's important that the instructors pay a lot of attention to each student while they learn to scuba dive! One instructor is enough to conduct a band or supervise a lot of people playing pickleball.*

Independent Practice and Review

Have your child complete the Lesson 4.3 Practice and Review workbook pages.

Lesson 7.3

Divide Mixed Numbers by Fractions

Purpose	Materials
<ul style="list-style-type: none"> Practice using “keep, change, flip” to divide a whole number by a fraction Use “keep, change, flip” to divide mixed numbers by fractions 	<ul style="list-style-type: none"> None
Memory Work <ul style="list-style-type: none"> What is the absolute value of a number? <i>The number’s distance from zero on the number line.</i> What is the opposite of a positive number? <i>The negative number with the same distance from zero (or the same absolute value).</i> What is the opposite of a negative number? <i>The positive number with the same distance from zero (or the same absolute value).</i> What is the opposite of zero? <i>Zero.</i> 	

As you teach this unit, keep in mind that it’s very common for procedural proficiency with fraction division to come before conceptual understanding. If your child struggles to understand the meaning of a fraction division problem, encourage her to follow the procedures to find the answer and then discuss how her answer matches the hands-on materials or printed diagrams. With repeated practice and ongoing conversations, the connection between the procedures and the conceptual meaning of fraction division will eventually click.

Warm-up (A): Practice Dividing a Whole Number by a Fraction

In the last lesson, you learned how to use reciprocals to divide a whole number by a fraction. Read aloud the word problem.

- What division problem can we use to solve this problem?** *3 divided by one-eighth.*
Write “ $3 \div \frac{1}{8}$.”
- What are the three steps for dividing by a fraction?** *Keep, change, flip.*
- Which part do we keep?** *The dividend. The 3.*
- Which part do we change?** *The division sign. What do we change it to?* *A multiplication sign.*
- Which part do we flip?** *The divisor. The one-eighth.*

Have your child use the steps to rewrite the division problem as a multiplication problem and solve.

Clara’s family makes 3 pies for Thanksgiving. If $\frac{1}{8}$ of a pie is one serving, how many servings of pie do they have?



$$3 \div \frac{1}{8} = \frac{3}{1} \times \frac{8}{1} = \frac{24}{1} = 24 \text{ servings}$$

If your child has trouble visualizing the problem, draw 3 circles and split each circle into eighths. **Each person gets one-eighth of a pie. There are 8 servings in each pie, so there are a total of 24 servings.**

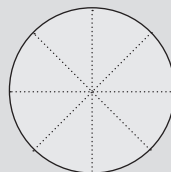
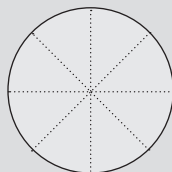
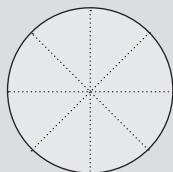

Activity (B): Use “Keep, Change, Flip” to Divide Mixed Numbers

Today, you’ll learn how to divide mixed numbers by fractions. Have your child read the text box aloud.

Divide Mixed Numbers
If the dividend is a mixed number, we first convert the mixed number to an improper fraction. Then, we follow the usual steps.

B

Ex. After Thanksgiving, Clara’s family has $1\frac{1}{2}$ pies left over. If $\frac{1}{8}$ of a pie is one serving, how many servings do they have?

$$1\frac{1}{2} \div \frac{1}{8} = ?$$

$$\frac{3}{2} \div \frac{1}{8} = ?$$

$$\frac{3}{2} \times \frac{8}{1} = \frac{12}{1} = 12 \text{ servings}$$

Read aloud the example.

- Clara’s family has 1 and one-half pies left, so we want to divide 1 and one-half by one-eighth.
- First, we convert the mixed number to an improper fraction. 1 and one-half equals what fraction? *Three-halves.*
- Then, we use “keep, change, flip” to rewrite the problem. What’s the reciprocal of one-eighth? 8. One-eighth goes into one whole 8 times.
- Three-halves times 8 equals 12. There are 12 servings. There are 8 servings in the whole pie and 4 servings in the leftover half.

Activity (C): Divide to Find the Number of Servings in Thanksgiving Foods

When you plan a holiday meal, it’s important to make sure you have enough food for everyone! We’ll use this list of portion sizes to help a family check that they have enough food to serve Thanksgiving dinner to 10 people.

Read aloud the first problem. **How many pounds of potatoes do they have? 7 and one-half pounds. They need one-half pound per person, so we’ll divide 7 and one-half by one-half to find the number of servings in the entire bag.**

Write “ $7\frac{1}{2} \div \frac{1}{2}$ ” and have your child follow the steps to solve. **How many servings are in the bag of potatoes? 15. That will be plenty for 10 people!** Have your child solve the rest of the problems in the same way.

Thanksgiving Planning for 10 People

Food	Amount per person
Cranberry sauce	$\frac{1}{4}$ c.
Stuffing	$\frac{3}{4}$ c.
Potatoes	$\frac{1}{2}$ lb.
Gravy	$\frac{1}{3}$ c.

The bag of potatoes weighs $7\frac{1}{2}$ lb. How many servings is that?

$$7\frac{1}{2} \div \frac{1}{2} \rightarrow \frac{15}{2} \div \frac{1}{2}$$

$$\frac{15}{2} \times \frac{2}{1} = \frac{15}{1} = 15$$

Grandma’s gravy recipe makes $4\frac{1}{2}$ c. How many servings is that?

$$4\frac{1}{2} \div \frac{1}{3} \rightarrow \frac{9}{2} \div \frac{1}{3}$$

$$\frac{9}{2} \times \frac{3}{1} = \frac{27}{2} = 13\frac{1}{2}$$

C

Uncle Joe’s stuffing recipe makes $8\frac{1}{2}$ c. How many servings is that?

$$8\frac{1}{2} \div \frac{3}{4} \rightarrow \frac{17}{2} \div \frac{3}{4}$$

$$\frac{17}{2} \times \frac{4}{3} = \frac{34}{3} = 11\frac{1}{3}$$

Aunt Mary’s cranberry sauce recipe makes $3\frac{3}{4}$ c. How many servings is that?

$$3\frac{3}{4} \div \frac{1}{4} \rightarrow \frac{15}{4} \div \frac{1}{4}$$

$$\frac{15}{4} \times \frac{4}{1} = \frac{15}{1} = 15$$

If your child needs more room, have her complete the problems on scrap paper.

After your child completes the problems, ask, **Do they have enough food for 10 people? Yes. How do you know? They have more than 10 servings of every dish.**

Independent Practice and Review

Have your child complete the Lesson 7.3 Practice and Review workbook pages.

Lesson 8.3

Compare Fractions and Decimals

Purpose	Materials
<ul style="list-style-type: none"> Practice converting common fractions to decimals Use common fractions to compare fractions and decimals 	<ul style="list-style-type: none"> Playing cards
Memory Work <ul style="list-style-type: none"> How many millimeters equal 1 centimeter? 10. How many centimeters equal 1 meter? 100. How many meters equal 1 kilometer? 1,000. How many grams equal 1 kilogram? 1,000. How many milliliters equal 1 liter? 1,000. 	

Warm-up (A): Convert Common Fractions to Decimals

In the last lesson, you wrote common fractions as decimals. It's very helpful to have these common fractions and their equivalent decimals memorized, so we'll practice them in your memory work in future lessons. Let's see how many of them you already know.

Have your child complete as many of the decimal equivalents as she knows. Help her use equivalent fractions (as in Lesson 8.2) to figure out the rest. For example, for $\frac{3}{5}$: **Three-fifths equals how many tenths? 6. So, three-fifths equals 0.6.**

$\frac{1}{2} = \underline{0.5}$	$\frac{1}{5} = \underline{0.2}$	$\frac{3}{5} = \underline{0.6}$
$\frac{1}{4} = \underline{0.25}$	$\frac{2}{5} = \underline{0.4}$	$\frac{4}{5} = \underline{0.8}$
$\frac{3}{4} = \underline{0.75}$		



Activity (B): Use Decimals to Compare Numbers

We can use fractions and their equivalent decimals to help compare numbers.

B

Use Decimals to Compare



Ex. Which is greater, $\frac{1}{4}$ or 0.23?

$\frac{1}{4} = 0.25$ 0.23

0.25 is greater than 0.23, so $\frac{1}{4}$ is greater than 0.23.

Ex. Which is greater, $\frac{1}{4}$ or $\frac{3}{10}$?

$\frac{1}{4} = 0.25$ $\frac{3}{10} = 0.3$

0.3 is greater than 0.25, so $\frac{3}{10}$ is greater than $\frac{1}{4}$.

In the first example, we want to compare a fraction and decimal.

- Read aloud the problem: *Which is greater, one-fourth or 0.23?*
- One-fourth equals what decimal?** 0.25.
- Which is greater, 0.25 or 0.23?** 0.25.
- So, one-fourth is greater than 0.23.**

In the second example, we want to compare two fractions. It's easier to compare them if we convert both fractions to decimals first.

- Read aloud the problem: *Which is greater, one-fourth or three-tenths?*
- One-fourth equals what decimal?** 0.25.
- Three-tenths equals what decimal?** 0.3.
- Which is greater, 0.25 or 0.3?** 0.3.

- **0.3 is greater than 0.25, so three-tenths is greater than one-fourth.**

Have your child use similar reasoning to complete the comparisons. First, have her write the decimal equivalent below each fraction. Then, have her compare the decimals to complete the problem.

$\frac{1}{2} < 0.5001$ $0.5 < 0.5001$	$\frac{1}{5} > 0.19$ $0.2 > 0.19$	$\frac{3}{4} < \frac{4}{5}$ $0.75 < 0.8$
--	--------------------------------------	---

Activity (C): Play Hit the Target

Play Hit the Target.

Hit the Target

Materials: Deck of playing cards, with 10s, jacks, queens, and kings removed (36 cards total)

Object of the Game: Win more points by creating decimals that are closer to the target numbers than those of your opponent.

Shuffle the cards and place them face down in one pile. Deal 4 cards to each player. Aces count as 1s.

Hit the Target has 5 rounds. In each round, both players choose 3 cards from their hand and use the digits on the cards to create a decimal. Each player writes their decimal on the scorecard.

Then, determine whose decimal is closer to the target. (You may need to convert the fraction to a decimal and subtract to find whose decimal is closer to the target.) Whoever has the decimal closer to the target wins a point. If both decimals are equally close to the target, both players win a point.

Player 1: Ace, 2, 7

Player 2: 2, 5, 8

Target: 0

Player 1 scorecard: 0.127

Player 2 scorecard: 0.258

Sample first round. 0.127 is closer to 0 than 0.258 is, so Player 1 wins the point.

Each player takes 3 new cards after each round (so that you always have 4 cards in your hand).

Play until you have completed all 5 rounds. Whoever wins more points wins the game.

Independent Practice and Review

Have your child complete the Lesson 8.3 Practice and Review workbook pages.

Lesson 9.3

Combine Like Terms to Simplify Expressions

Purpose	Materials
<ul style="list-style-type: none"> Practice evaluating an expression Identify terms and constants in an expression Add or subtract to combine terms and simplify expressions 	<ul style="list-style-type: none"> Counters
Memory Work	<ul style="list-style-type: none"> What do we call a letter that stands for a number? <i>A variable.</i> What do we call a number multiplied by a variable? <i>A coefficient.</i>

Warm-up (A): Evaluate a Long Expression

We'll use boxes of marbles and loose marbles to represent expressions again today. Every box has the same number of marbles, but we don't know how many marbles are in each box. We'll use m to represent the number of marbles in each box.

Evaluating this long expression prepares your child to learn how to simplify expressions in the next activity.

This picture shows 2 boxes plus 3 loose marbles plus 1 box plus 1 loose marble. So, the matching expression is $2m$ plus 3 plus m plus 1.

Have your child substitute 20 for m and then evaluate the expression. If m equals 20, how many marbles are there in all? 64.

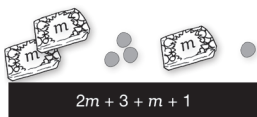

Evaluate the expression for $m = 20$.

$2 \cdot 20 + 3 + 20 + 1$									
$40 + 3 + 20 + 1 = 64$									

A

Activity (B): Identify Terms and Constants in Expressions

Today, you'll learn how to simplify long expressions like the one in part A to make them easier to evaluate. You'll also learn two new math vocabulary words: *term* and *constant*. Have your child read the top of the text box aloud.

Terms and Constants

The **terms** of an expression are the parts that are added or subtracted together.

Terms without variables are called **constants**, because they stay constant and don't change.

Like terms are terms that are like each other.

- Terms with the same variable are like terms.
- Constants are like terms.

B

Ex. How many terms are in this expression? How many constants?

$2m + 3 + m + 1$ $2m + 3 + m + 1$

4 terms 2 constants

Ex. Identify the like terms in this expression.

$2m + 3 + m + 1$

2m and m both have the same variable, so they are like terms. 3 and 1 are both constants, so they are like terms.

The example expression is the same expression you evaluated in part A.

- To find the terms in an expression, look for the parts of the expression that are separated by a plus sign or minus sign.
- How many terms are in the example? 4. What are the terms? $2m$, 3, m , and 1.

Read aloud the first practice expression: ***2m plus 3m.***

- **What are the like terms in this expression? *2m* and *3m*.**
- **There is a plus sign between the terms, so we add their coefficients. What's 2 plus 3? 5. So, *2m plus 3m* equals *5m*.**
- **Point to the boxes above the problem. 2 boxes plus 3 boxes equals 5 boxes. No matter how many marbles are in each box, you can multiply the number of marbles in each box by 5 to find the total number of marbles.**

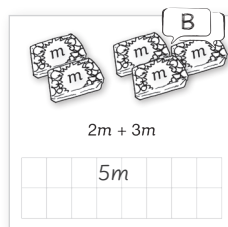

Read aloud the second expression: ***4m minus m.***

- **What are the like terms in this expression? *4m* and *m*.**
- **There is a minus sign between the terms, so we subtract their coefficients.**
- **When a variable doesn't have a coefficient, we understand it to have a coefficient of 1. 4 minus 1 equals 3, so *4m minus m* equals *3m*.**
- **Point to the boxes above the problem. 4 boxes minus 1 box equals 3 boxes. To find the total number of marbles, we multiply the number of marbles in each box by 3.**

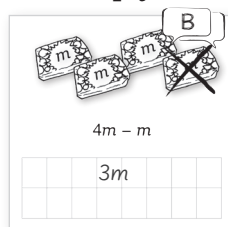

Read aloud the third expression: ***2 plus m plus 3.***

- **Only one term has *m* as its variable, so we don't need to combine it with anything.**
- **What are the like terms in this expression? *2* and *3*. 2 plus 3 equals 5.**
- **The expression simplifies to *m plus 5*. When we simplify expressions, we write the term with the variable before the constant term.**
- **Point to the boxes above the problem. 2 marbles plus 1 box plus 3 marbles equals 1 box plus 5 loose marbles. To find the total number of marbles, we take the number of marbles in the box and add 5.**

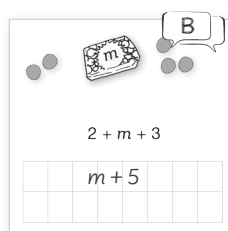

Writing the term with the variable before the constant term is simply a mathematical convention.

Activity (C): Play Four in a Row

Play Four in a Row. Your child may simplify the expressions mentally or write them on scrap paper.

Four in a Row

Materials: 10 counters per player, with a different color for each player

Object of the Game: Be the first player to place counters in 4 boxes in a row, either horizontally, vertically, or diagonally.

On your turn, choose an expression in a lighter box on the game board. Find the equivalent expression in a darker box. Use 2 counters to cover both boxes. For example, if you choose $x + x + x$ as your expression, cover both $x + x + x$ and $3x$ with counters. Play then passes to the other player.

Continue until one player covers 4 boxes in a row, either horizontally, vertically, or diagonally.

Answer Key:

$x + x + x = 3x$	$4x + 5$	$5x - 3x + 4 = 2x + 4$	$6x$
$x + 9$	$x + 6x = 7x$	$9x$	$2 + 3 + 4x = 4x + 5$
$7x - 2x = 5x$	$8x$	$8x - 2x = 6x$	$2x + 4$
$7x$	$10x - x = 9x$	$2x + 1$	$x + 7 + 2 = x + 9$
$2x + 5 - 4 = 2x + 1$	$3x$	$x + 7x = 8x$	$5x$

Independent Practice and Review

Have your child complete the Lesson 9.3 Practice and Review workbook pages.

Lesson 10.10

Enrichment (Optional)

Purpose	Materials
<ul style="list-style-type: none"> • Review memory work • Appreciate how math can be used in real-life situations • Use a percentage to describe the fraction of shots made in basketball • Summarize what your child has learned and assess your child's progress 	<ul style="list-style-type: none"> • <i>What's the Point of Math?</i> • Wad of paper and trash can, or basketball and basketball hoop

Warm-up: Review Memory Work

Quiz your child on any of the memory work items that he struggled with during this unit.

Math Book: *What's the Point of Math?*

Read pages 28-31 in *What's the Point of Math?*

Enrichment Activity: Use Percentages to Describe Baskets

We often use percentages to describe players' performances in sports. For example, in basketball, a player's free-throw percentage tells what percentage of free throws they make. In baseball, a player's on-base percentage tells what percentage of the time they reach a base.

Today, we'll use a percentage to describe how many baskets you make.

- If you have access to a real basketball hoop, have your child attempt 20 shots from the same spot.
- If you don't have access to a real basketball hoop, wad up a piece of paper to use as a ball. Have your child stand about 8 feet from a trash can and attempt to throw the paper wad into the trash can 20 times.

Then, have your child write a fraction that shows what fraction of the shots he made. Have him use an equivalent fraction to express this fraction as a percentage.

$$\frac{6}{20} = \frac{30}{100} = 30\%$$

Sample fraction and percentage for a child who made 6 out of 20 shots.

Unit Wrap-Up

Have your child complete the Unit 10 Wrap-Up.

Lesson 11.3



Solve Equations, Part 1

Purpose	Materials
<ul style="list-style-type: none"> Preview the concept of changing both sides of an equation in the same way Solve addition equations Use substitution to check solutions to equations 	<ul style="list-style-type: none"> Die
Memory Work <ul style="list-style-type: none"> What percentage is equivalent to one-half? 50%. One-third? 33 and one-third percent. Two-thirds? 66 and two-thirds percent. One-fourth? 25%. Three-fourths? 75%. One-fifth? 20%. Two-fifths? 40%. Three-fifths? 60%. Four-fifths? 80%. 	

Warm-up (A): Cross Out Marbles to Keep the Scale Balanced

In equations, the two sides equal each other, just like a scale that's in balance. To warm up, we'll cross out marbles on these scales. For each scale, we'll cross out the same number of marbles on each side so that the scale stays in balance.

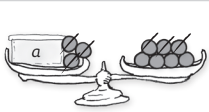
The directions for the first exercise say to cross out 3 loose marbles on each side of the scale. Have your child cross out 3 marbles on each side of the scale. The box labeled a is all by itself on the left side of the scale now. How many marbles remain on the right side of the scale? 4. So, there must be 4 marbles inside the box to balance the scale. Write 4 in the blank. Repeat with the final two exercises.

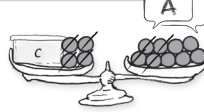
 <p>Cross out 3 loose marbles on each side of the scale.</p> <p>$a = \underline{\quad 4 \quad}$</p>	 <p>Cross out 1 loose marble on each side of the scale.</p> <p>$b = \underline{\quad 3 \quad}$</p>	 <p>Cross out 4 loose marbles on each side of the scale.</p> <p>$c = \underline{\quad 5 \quad}$</p>
---	--	--

If your child is skeptical, say: **Before we crossed out the loose marbles, there were 7 loose marbles on the right side of the scale. If you put 4 marbles in the box, there would be 7 marbles on the left side of the scale, too.**

Activity (B): Solve Addition Equations

In the last lesson, you learned how to check whether a number is a solution to an equation. You substituted the number into the equation and checked whether the two sides of the equation were equal.

Today, you'll learn how to find the solution to an addition equation. Have your child read the text box aloud.

Solve Equations, Part 1

To solve an equation, we change both sides until we have the variable by itself on one side of the equation.

The two sides of an equation are like the two sides of a scale. If you change one side of the equation, you must change the other side in the same way.

1. Identify what happens to the variable in the equation. Do the opposite operation to both sides of the equation.
2. Simplify both sides.
3. Substitute the solution into the equation to check your answer.

Ex. Solve: $x + 18 = 27$

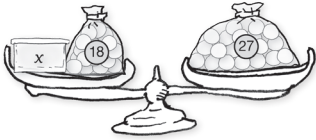

In this equation, 18 is added to x . So, we subtract 18 from both sides to get x by itself on one side of the equation.

$$\begin{array}{r} x + 18 = 27 \\ - 18 \quad - 18 \\ \hline x = 9 \end{array}$$

Check:
 $9 + 18 \stackrel{?}{=} 27$
 $27 = 27 \checkmark$

The example shows how to find the solution to an addition equation. The line down the middle of the equals signs helps us visually separate the two sides of the equation from each other.

- Read aloud the equation: ***x plus 18 equals 27.***
- **What happens to the variable in this equation?** *We add 18 to it.*
- **What's the opposite of adding 18 to a number?** *Subtracting 18 from the number.*
- **So, we subtract 18 from both sides of the equation. We write "minus 18" below both sides of the equation.**
- **Then, we subtract. On the left side, we have x plus 18, minus 18. Subtracting 18 cancels out adding 18, so we're left with x by itself.**
- **On the right side, we have 27 minus 18. 27 minus 18 equals 9. So, x equals 9.**
- **Last, we substitute 9 back into the equation to check that it's a solution. 9 plus 18 equals 27, so 9 is the solution to the equation.**
- **Point to the scale. Subtracting 18 from both sides of the equation is like crossing out 18 marbles from both sides of the scale. You're left with the box labeled x on the left side and 9 marbles on the right side. So, x must equal 9.**
- **If you put any other number of marbles in the box, the scale won't be balanced.**

In Lesson 11.2, some of the equations had more than one solution. For the rest of the unit, every equation with one variable has only one solution.

Demonstrate how to solve the first practice problem.

- Read aloud the equation: ***p plus 12 equals 47.***
- **First, we use a highlighter to draw a vertical line through the equals sign. We'll write all our equals signs on this line so that it's easy to see the two sides of the equation.** Draw a vertical line through the equals sign as shown.
- **What happens to the variable in this equation?** *We add 12 to it.*
- **What's the opposite of adding 12 to a number?** *Subtracting 12 from the number.*
- **So, we subtract 12 from both sides of the equation.** Write "-12" below both sides of the equation as shown.
- **Then, we subtract. On the left side, we have p plus 12, minus 12. Subtracting 12 cancels out adding 12, so we cross out both numbers.** Draw a slash through +12 and -12 as shown. **We're left with p by itself on the left side.**
- **What's 47 minus 12?** *35. So, p equals 35.* Write " $p = 35$ " as shown. Write the equals sign on top of the highlighter line.

Lesson 13.2

Surface Area of Rectangular Prisms and Cubes

Purpose	Materials
<ul style="list-style-type: none"> Find the area of a rectangular prism's net Find the surface area of rectangular prisms and cubes Analyze 3-D solids and make a plan before finding surface area 	<ul style="list-style-type: none"> Rectangular Prisms (Blackline Master 6) Tape
Memory Work <ul style="list-style-type: none"> What do we call a 3-D solid with 6 rectangular faces? <i>Rectangular prism.</i> What do we call a 3-D solid with 6 square faces? <i>Cube.</i> What do we call a 3-D solid with 2 triangular faces connected by 3 rectangular faces? <i>Triangular prism.</i> What do we call a 3-D solid with a flat face connected to a triangular face along each side? <i>Pyramid.</i> 	

You will introduce your child to the concept of surface area in this lesson. While the concept is usually easy for children to grasp, they often have trouble keeping track of all the steps in their calculations. See the Unit 13 **Teaching Math with Confidence** for tips to help your child solve surface area problems.

Warm-up (A): Find the Area of a Rectangular Prism's Net

Show your child the net in part A. **If you folded up this net, what 3-D solid would you create?** *A rectangular prism.* Give your child the matching net from Blackline Master 6. Have him fold and tape it into a rectangular prism.

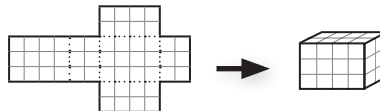

The printed net has two dimensions, so we can find its area. Have your child find the area of each rectangle in the net. Then, have him add to find the total area of the net.

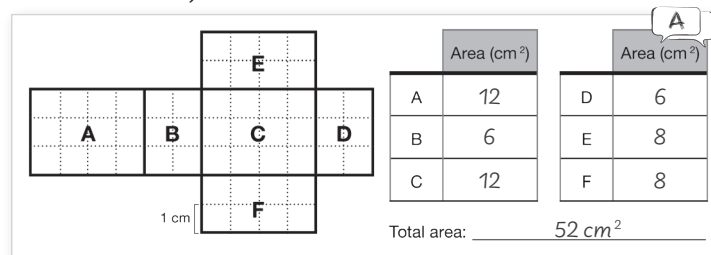

Which pairs of rectangles have the same area? *A and C, B and D, E and F.* These faces are parallel to each other in the rectangular prism. Parallel faces in rectangular prisms always have the same area as each other.

Activity (B): Find the Surface Area of a Rectangular Prism or Cube

Today, you'll learn how to find the surface area of rectangular prisms and cubes. The surface area is the total area of all the faces.

This box has the same dimensions as the rectangular prism in part A. To find its surface area, we first find the area of each face. Then, we add up the areas of all the faces to find the total surface area.

Your child already found the surface area of this rectangular prism when he found the total area of the net in part A. Both methods are included so that your child understands that the surface area of a solid and the area of its net are equal.

B

Surface Area of Rectangular Prisms and Cubes

The surface area of a 3-D solid is the total area of all its faces. To find surface area, we find the area of each face and then add the areas.

Ex. What is the surface area of the box?

Area of each green face: $4\text{ cm} \times 3\text{ cm} = 12\text{ cm}^2$

Area of each blue face: $2\text{ cm} \times 3\text{ cm} = 6\text{ cm}^2$

Area of each purple face: $4\text{ cm} \times 2\text{ cm} = 8\text{ cm}^2$

$12\text{ cm}^2 + 12\text{ cm}^2 + 6\text{ cm}^2 + 6\text{ cm}^2 + 8\text{ cm}^2 + 8\text{ cm}^2 = 52\text{ cm}^2$

Use the following questions to discuss the example:

- **What are the dimensions of each green face?** *4 centimeters by 3 centimeters. So, what's the area of each green face?* *12 square centimeters.*
- **What are the dimensions of each blue face?** *2 centimeters by 3 centimeters. So, what's the area of each blue face?* *6 square centimeters.*
- **What are the dimensions of each purple face?** *4 centimeters by 2 centimeters. So, what's the area of each purple face?* *8 square centimeters.*
- **To find the surface area of the box, we add up the area of all the faces.**
- **Point to $12\text{ cm}^2 + 12\text{ cm}^2$.** **There are two green faces, so we include 12 square centimeters in the sum twice. We do the same for the two blue faces and two purple faces.**
- **12 plus 12 plus 6 plus 6 plus 8 plus 8 equals 52, so the surface area of the box is 52 square centimeters.**
- **Does it make sense that the answer would have square centimeters as the unit?**
Yes. Why? Sample answer: We measure area with square units.

Write the following expression on scrap paper (or show the printed expression to your child). We could also use multiplication to add the area of the faces more quickly. We could multiply 2 times 12 to find the area of both green faces, multiply 2 times 6 to find the area of both blue faces, and multiply 2 times 8 to find the area of both purple faces. The sum of these products equals 52. We get the same answer either way.

$$\begin{aligned}
 &2 \times 12\text{ cm}^2 + 2 \times 6\text{ cm}^2 + 2 \times 8\text{ cm}^2 \\
 &24\text{ cm}^2 + 12\text{ cm}^2 + 16\text{ cm}^2 \\
 &52\text{ cm}^2
 \end{aligned}$$

Activity (B): Make a Plan Before Finding Surface Area

Have your child fold and tape the remaining nets from Blackline Master 6.

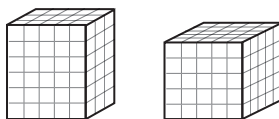

Now, we'll find the surface area of these solids. The hardest part of finding surface area is keeping track of all the faces of the solid! It's important to make sure you include every face and don't include any face more than once. It helps if you count the number of faces, identify faces with the same area, and make a plan before you start writing equations.

Show your child the paper solid that matches the first printed rectangular prism. Demonstrate how to analyze the solid and make a plan to find its surface area. Use the paper solid as needed to help your child count the faces and identify equal faces.

- **What kind of 3-D solid is this?** *Rectangular prism.*
- **How many faces does it have?** 6.
- **Which faces have the same area?** *The pairs of parallel faces.*
- **There are 3 pairs of parallel faces. So, let's find the area of one face in each pair. Then, we'll multiply the area of each face by 2 and add the products to find the total surface area.**

Help your child find the area of one face from each pair of parallel faces. Then, help him write an expression that tells the total surface area of the solid.

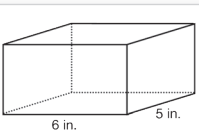

Surface area: 126 in.²

$6 \times 5 = 30$					
$3 \times 5 = 15$	$6 \times 3 = 18$				
$2 \cdot 30 + 2 \cdot 15 + 2 \cdot 18$					
$60 + 30 + 36$					
126					

There are many numbers in these problems, so writing the corresponding unit for every number can feel tedious. Your child does not need to include the units with every number unless he gets confused about which units he is using. Require him to use the correct units for his final answer.

Your child may use a different method to find the surface area of the solid. Accept any method as long as he writes out the matching equations and finds the correct answer.

Use the following questions to help your child make a plan to find the surface area of the second solid.

- **What kind of 3-D solid is this?** *Cube.*
- **How many faces does it have?** 6.
- **Which faces have the same area?** *All 6 of them.*
- **What's your plan for finding the cube's surface area?** *Sample answer: Find the area of one face and then multiply the area by 6.*

Then, have your child use his plan to find the cube's surface area.

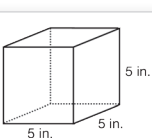

Surface area: 150 in.²

	$5 \times 5 = 25$				
	$25 \times 6 = 150$				

Independent Practice and Review

Have your child complete the Lesson 13.2 Practice and Review workbook pages.

Lesson 14.4

Speed

Purpose	Materials
<ul style="list-style-type: none"> Explore the relationship between speed, time, and distance Divide distance by time to find speed 	<ul style="list-style-type: none"> None
Memory Work <ul style="list-style-type: none"> What do we call a letter that stands for a number? <i>A variable.</i> What do we call a number multiplied by a variable? <i>A coefficient.</i> What do we call the parts of an expression that are added or subtracted? <i>Terms.</i> What do we call a term with only a number and no variable? <i>A constant.</i> 	

Warm-up (A): Explore Speed with a Critter Race

This warm-up activity helps your child kinesthetically understand the difference between different speeds. Make sure not to skip this simple hands-on activity.

In the last few lessons, you learned how to find unit rates and unit prices. You wrote each quantity above or below the fraction bar and then divided to find the unit rate.

Speed is a special type of unit rate that compares distance to one unit of time. Today, you'll learn how to find speed. We'll warm up by finding animals' speeds in a 6-inch critter race.

The ladybug travels the 6 inches in 6 seconds. We want to find the ladybug's speed in inches per second. So, write the number of inches above the fraction bar and the number of seconds below the fraction bar. Have your child find the ladybug's speed and complete the blank.

The ladybug travels 6 inches in 6 seconds.

6 in.	=	1 in.
6 sec.		sec.

1 inches per second



What is the ladybug's speed? *1 inch per second.* I'll use my finger to act out the ladybug's race. Put your finger at the Start position. Say "Start" and then gradually move your finger along the racecourse at a speed of 1 inch per second. Count "1 Mississippi" as you move from 0 to 1, "2 Mississippi" as you move from 1 to 2, and so on. Then, have your child act out the ladybug's race in the same way.

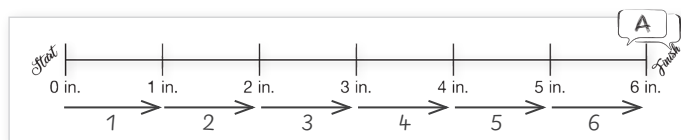

Count each number as you move your finger the corresponding distance.

Use whatever word or phrase your family usually uses to count seconds accurately (like "potato" or "one thousand").

Have your child calculate the snail's speed and trace the snail's race with his finger. Then, repeat for the ant.

The snail travels 6 inches in 12 seconds.

6 in.	=	1 in.
12 sec.	=	2 sec.

$\frac{1}{2}$ inches per second

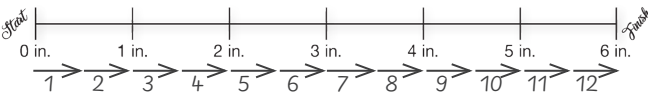

The ant travels 6 inches in 3 seconds.

6 in.	=	2 in.
3 sec.	=	1 sec.

2 inches per second

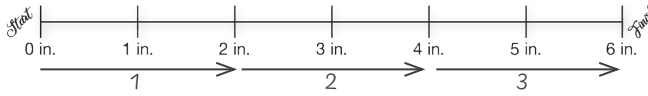

Which animal is fastest? *The ant.* Which animal is slowest? *The snail.* If the animals all start at the same time, which one wins the race? *The ant.*

Activity (B): Find Speed

We divide distance by time to find speed, just like you did in part A. Have your child read the text box aloud.

Speed

Speed is a special type of unit rate that compares distance to one unit of time.

$$\frac{\text{distance}}{\text{time}} = \text{speed}$$

Measurement units for speed always include both a distance unit and a time unit. We sometimes use p to stand for "per" in measurement units for speed.

miles per hour
miles/hour
mph

Ex. James is training for a marathon. On Sunday, he ran 12 miles. It took him 2 hours. What was his speed (in miles per hour)?

$$\frac{12 \text{ miles}}{2 \text{ hours}} = 6 \text{ miles per hour}$$

Ex. On Monday, James ran 10 miles. It took him $1\frac{1}{2}$ hours. What was his speed (in miles per hour)?

$$\frac{10 \text{ miles}}{1\frac{1}{2} \text{ hours}} \rightarrow 10 \div 1\frac{1}{2}$$

$$\frac{10}{1} \div \frac{3}{2} \rightarrow \frac{10}{1} \times \frac{2}{3} = \frac{20}{3} = 6\frac{2}{3} \text{ mph}$$

Read the first example problem aloud.

- We want to find James's speed in miles per hour. So, we divide the number of miles by the number of hours. We write 12 miles above the fraction bar and 2 hours below the fraction bar.
- Both numbers are whole numbers, so we divide mentally. 12 divided by 2 equals 6. We have miles over hours, so the answer's label is miles per hour.
- James ran at a speed of 6 miles per hour.

Read the second example aloud.

- Again, we want to find James's speed in miles per hour. So, we divide the number of miles by the number of hours. We write 10 miles above the fraction bar and 1 and one-half hours below the fraction bar.
- There is a mixed number in the denominator. The fraction bar represents division, so we rewrite the problem with the division symbol to make it easier to solve. Then, we use keep, change, flip to divide 10 by 1 and one-half. 10 divided by 1 and one-half equals 6 and two-thirds.
- Again, we have miles over hours, so the answer's label is miles per hour. "Mph" is an abbreviation for miles per hour.
- This time, James ran at a speed of 6 and two-thirds miles per hour.

James keeps a record of all his runs during the same week. We'll use his log to find how fast he ran each day. Have your child divide distance by time to find the speed for each run. Remind him as needed to write the answers as mixed numbers in simplest form. Have him write his equations on scrap paper if he needs more space.

<i>Running Log</i>	Distance (mi.)	Time (hr.)	Speed (mph)
Tuesday	18	3	6
Wednesday	19	3	$6\frac{1}{3}$
Thursday	21	$4\frac{2}{3}$	$4\frac{1}{2}$
Saturday	10	$1\frac{1}{4}$	8

B

$$\frac{18 \text{ mi.}}{3 \text{ hr.}} = 6 \text{ mph}$$

$$\frac{19 \text{ mi.}}{3 \text{ hr.}} = 6\frac{1}{3} \text{ mph}$$

$$\frac{21 \text{ mi.}}{4\frac{2}{3} \text{ hr.}} \rightarrow 21 \div 4\frac{2}{3} \rightarrow \frac{21}{1} \div \frac{14}{3}$$

$$\frac{3}{1} \times \frac{3}{14} = \frac{9}{2} = 4\frac{1}{2} \text{ mph}$$

$$\frac{10 \text{ mi.}}{1\frac{1}{4} \text{ hr.}} \rightarrow 10 \div 1\frac{1}{4} \rightarrow \frac{10}{1} \div \frac{5}{4}$$

$$\frac{4}{1} \times \frac{2}{5} = 8 \text{ mph}$$

If your child has trouble solving these problems, remind him that the fraction bar represents division:

- If the numbers above and below the fraction bar are whole numbers, we simplify the fraction or write the fraction as a mixed number in simplest form.
- If the numerator or denominator contains a fraction, we rewrite the problem with the division symbol and then use keep, change, flip to solve.

Use the following questions to discuss the finished running log:

- Which day did James run the longest distance? *Thursday.*
- Which day did James run for the longest amount of time? *Thursday.*
- Which day did James run at the fastest speed? *Saturday.*

Independent Practice and Review

Have your child complete the Lesson 14.4 Practice and Review workbook pages.

Lesson 15.2

Use Decimal Multiplication to Find Percentages

Purpose	Materials
<ul style="list-style-type: none"> Practice writing percentages as decimals Use decimal multiplication to find a percentage of a whole number 	<ul style="list-style-type: none"> None
Memory Work	<ul style="list-style-type: none"> What's the basic formula for speed, time, and distance? <i>Speed times time equals distance.</i> What does distance divided by time equal? <i>Speed.</i> What does distance divided by speed equal? <i>Time.</i>

In this lesson, your child will learn how to use decimal multiplication to find a percentage of a whole number. In Lesson 15.5, he will learn how to use decimal multiplication to find a percentage of a decimal.

Warm-up (A): Practice Writing Percentages as Decimals

In Unit 10, you learned about percentages. What does percent mean? *Out of 100.* Have your child complete the exercises. He should complete the numerator in each fraction and then write the matching decimal.

$53\% = \frac{53}{100} = \underline{0.53}$	$9\% = \frac{9}{100} = \underline{0.09}$	$176\% = \frac{176}{100} = \underline{1.76}$
$70\% = \frac{70}{100} = \underline{0.7}$	$41\% = \frac{41}{100} = \underline{0.41}$	$208\% = \frac{208}{100} = \underline{2.08}$

For 70%, your child may write either 0.70 or 0.7. **We usually write 0.7 as the decimal equivalent for 70%, since it's simpler.**

Activity (B): Use Decimal Multiplication to Find Percentages

In Unit 10, you learned how to use fractions to find a percentage of a whole number. You converted the percentage to a fraction. Then, you multiplied the fraction by the whole number.

Today, you'll learn how to use decimals to find a percentage of a whole number. It's very similar to how we use fractions to find a percentage of a number. You convert the percentage to a decimal, then you multiply the decimal by the number. Have your child read the text box aloud.

Use Decimal Multiplication to Find Percentages

In math, "of" often means multiply. We can use decimals to find a percentage of a number.

- Convert the percentage to a decimal.
- Multiply the decimal by the number.

Ex. Faith buys a board game for \$38. She lives in a state that charges 6% sales tax. How much is the sales tax on the board game?

What is 6% of 38?

$6\% = 0.06$

4	
38	
× 0.06	
\$2.28	

Decimal digits
 0
 + 2
 2



Ex. What is the total cost of the game?

$\$38.00 + \$2.28 = \mathbf{\$40.28}$

In the example, Faith lives in a state that charges 6% sales tax. That means that the store finds 6% of the price. Then, they add this amount to the price to find the total cost. The store later pays the sales tax amount to the state government.

- When we solve percentage problems, it often helps to say in words what you're trying to find. We want to find 6% of 38.
- What decimal is equivalent to 6%? 0.06 . "Of" means multiply, so we'll multiply 0.06 times 38.
- To multiply a decimal by a whole number, we multiply like usual. Then, we count the number of decimal digits in the factors and write the decimal point in the product to match.
- What's 0.06 times 38? 2.28 . So, the sales tax is \$2.28.
- We add the sales tax to the price to find the total cost. What is the total cost of the game? \$40.28.

You could also set up this multiplication problem with 0.06 on top and 38 on the bottom, since the answer to a multiplication problem does not change if you write the factors in a different order. When your child solves decimal multiplication problems, encourage him to write the number with more non-zero digits on top, and the number with fewer non-zero digits on the bottom. This usually makes the multiplication easier.

Activity (C): Play Pop the Percentage (1-Player Game)

Explain to your child how to play Pop the Percentage. Then, have him complete this one-player game. Encourage him to look at the choices and use percentage-fraction equivalents to help estimate the better answer.

- For 53% of \$60: **Your choices are less than \$30 or more than \$30. 30 is what percent of 60? 50%.** If your child isn't sure, point out that 30 is half of 60, and one-half equals 50%. **Is 53% less than or greater than one-half? Greater. So, 53% of 60 must be greater than 30.**
- For 6% of \$80: **Your choices are less than \$8 or more than \$8. 8 is what percent of 80? 10%.** If your child isn't sure, point out that 8 is one-tenth of 80, and one-tenth equals 10%. **Is 6% less than or greater than 10%? Less. So, 6% of 80 must be less than 8.**
- For 176% of \$20: **Your choices are less than \$40 or more than \$40. \$40 is what percent of 20? 200%.** If your child isn't sure, point out that 100% of 20 is 20, so 200% of 20 is 40. **Is 176% less than or greater than 200%? Less. So, 176% of 20 must be less than 40.**

Pop the Percentage

Materials: None

Object of the Game: Choose the balloon that describes the answer to the percent problem above it.

For each problem, circle the balloon that you think matches the answer to the percent problem above the balloon. Then, use decimal multiplication to find the exact answer. If you circled the correct balloon, draw an X on the balloon to "pop" it.

You win the game if you pop all 3 balloons.

Directions continued on next page.

Answer Key:

53% of \$60	6% of \$80	176% of \$20 C																																				
<div style="display: flex; justify-content: space-around;"> <div style="text-align: center;"> less than \$30 </div> <div style="text-align: center;"> more than \$30 </div> </div>	<div style="display: flex; justify-content: space-around;"> <div style="text-align: center;"> less than \$8 </div> <div style="text-align: center;"> more than \$8 </div> </div>	<div style="display: flex; justify-content: space-around;"> <div style="text-align: center;"> less than \$40 </div> <div style="text-align: center;"> more than \$40 </div> </div>																																				
<table style="border-collapse: collapse; margin: auto;"> <tr><td style="padding: 0 10px;"> </td><td style="text-align: center;">1</td><td style="padding: 0 10px;"> </td></tr> <tr><td style="padding: 0 10px;"> </td><td style="text-align: center;">0.53</td><td style="padding: 0 10px;"> </td></tr> <tr><td style="padding: 0 10px;"> </td><td style="text-align: center;">× 60</td><td style="padding: 0 10px;"> </td></tr> <tr><td colspan="3" style="border-top: 1px solid black; padding-top: 5px;">\$ 31.80</td></tr> </table>		1			0.53			× 60		\$ 31.80			<table style="border-collapse: collapse; margin: auto;"> <tr><td style="padding: 0 10px;"> </td><td style="text-align: center;">2</td><td style="padding: 0 10px;"> </td></tr> <tr><td style="padding: 0 10px;"> </td><td style="text-align: center;">80</td><td style="padding: 0 10px;"> </td></tr> <tr><td style="padding: 0 10px;"> </td><td style="text-align: center;">× 0.06</td><td style="padding: 0 10px;"> </td></tr> <tr><td colspan="3" style="border-top: 1px solid black; padding-top: 5px;">\$ 4.80</td></tr> </table>		2			80			× 0.06		\$ 4.80			<table style="border-collapse: collapse; margin: auto;"> <tr><td style="padding: 0 10px;"> </td><td style="text-align: center;">11</td><td style="padding: 0 10px;"> </td></tr> <tr><td style="padding: 0 10px;"> </td><td style="text-align: center;">1.76</td><td style="padding: 0 10px;"> </td></tr> <tr><td style="padding: 0 10px;"> </td><td style="text-align: center;">× 20</td><td style="padding: 0 10px;"> </td></tr> <tr><td colspan="3" style="border-top: 1px solid black; padding-top: 5px;">\$ 35.20</td></tr> </table>		11			1.76			× 20		\$ 35.20		
	1																																					
	0.53																																					
	× 60																																					
\$ 31.80																																						
	2																																					
	80																																					
	× 0.06																																					
\$ 4.80																																						
	11																																					
	1.76																																					
	× 20																																					
\$ 35.20																																						

Remind your child to write the number with more non-zero digits on top, and the number with fewer non-zero digits on the bottom.

Independent Practice and Review

Have your child complete the Lesson 15.2 Practice and Review workbook pages.

Scope and Sequence

Unit	Objectives
Unit 1 Order of Operations, Exponents, and Prime Factors	<ul style="list-style-type: none"> • Use exponents to express repeated multiplication • Memorize square numbers from 1^2 to 12^2 • Use exponents to express powers of 10 • Use the order of operations to evaluate expressions with exponents • Use a dot to represent multiplication and use a fraction bar to represent division • Use the distributive property or cancelling to simplify and evaluate expressions • Identify prime and composite numbers to 100 • Use factor trees to find all prime factors of a number and write the number's prime factorization • Use two numbers' prime factorizations to find their greatest common factor (GCF)
Unit 2 Review Fractions	<ul style="list-style-type: none"> • Review equivalent fractions, mixed numbers, improper fractions, and simplest form • Use cancelling to simplify fractions • Use common denominators to compare three fractions with different denominators • Use common denominators to add and subtract three fractions or mixed numbers with different denominators • Review how to find the number of objects in a fractional part of a set • Use bar models to solve multi-step word problems that involve fractional parts of sets, including find-a-part, find-the-whole, and comparison problems
Unit 3 Area of Parallelograms and Triangles	<ul style="list-style-type: none"> • Review the formulas for the perimeter or area of a rectangle • Multiply or divide measurement units • Use formulas to find the area of a parallelogram or triangle • Split shapes into triangles, parallelograms, or rectangles and add or subtract to find total area
Unit 4 Ratios	<ul style="list-style-type: none"> • Write ratios to describe relationships between quantities • Simplify ratios and tell whether ratios are equivalent • Understand that combinations with equivalent ratios are proportional to each other • Use the ratio between two quantities along with one of the quantities to find the other quantity • Use the ratio between two quantities to scale the quantities in proportion to each other • Use ratios to find fractions of a whole amount and vice versa • Use ratios and fractions to solve comparison problems • Use the ratio between two quantities and the sum of the quantities (or the difference between the quantities) to find each quantity
Unit 5 Multiply Fractions and Mixed Numbers	<ul style="list-style-type: none"> • Multiply fractions, whole numbers, and mixed numbers • Use cancelling to simplify fraction multiplication problems before solving • Multiply 3 or more fractions • Use fraction multiplication to solve real-world problems that involve finding a fraction of a quantity or equal groups of a quantity • Use fraction multiplication to find the area of rectangles, parallelograms, or triangles with fractional dimensions

Unit	Objectives
Unit 6 Positive and Negative Numbers on the Number Line and Coordinate Plane	<ul style="list-style-type: none">• Use positive and negative numbers to describe real-life situations• Compare positive and negative numbers and find distances between them on the number line• Find the absolute values or opposites of positive and negative numbers• Identify and plot points on the coordinate plane with both positive and negative coordinates• Find the horizontal or vertical distance between points on the coordinate plane• Find the perimeter or area of shapes on the coordinate plane
Unit 7 Divide Fractions and Mixed Numbers	<ul style="list-style-type: none">• Find reciprocals and understand that the reciprocal of a number tells how many times the number “goes into” one whole• Use reciprocals to rewrite fraction division problems as multiplication problems and solve• Divide fractions and mixed numbers• Use the relationship between the dividend and divisor to predict whether a quotient will be greater than, less than, or equal to one whole• Solve division word problems that involve fractions, whole numbers, and mixed numbers
Unit 8 Review Decimals	<ul style="list-style-type: none">• Extend decimal place value to the ten-thousandths-place• Review how to add and subtract decimals• Use equivalent fractions with base-ten denominators (like 10 or 100) to convert fractions to decimals• Use common fractions (like $\frac{1}{2}$ or $\frac{1}{5}$) to compare fractions and decimals• Review how to multiply and divide decimals by 10, 100, or 1,000• Review how to multiply decimals by whole numbers• Review how to divide decimals by whole numbers and round the quotient to a given decimal place
Unit 9 Expressions	<ul style="list-style-type: none">• Write expressions with one or two variables to describe real-life situations• Evaluate expressions for given values of the variables• Identify terms, coefficients, variables, and constants in expressions• Combine like terms or use multiplication properties to simplify expressions with one or two variables
Unit 10 Percentages	<ul style="list-style-type: none">• Use percentages to represent parts of a whole• Convert percentages to decimals (and vice versa)• Use equivalent fractions with 100 as the denominator to convert fractions to percentages (and vice versa)• Memorize percent equivalents for common fractions• Use mental math and fraction multiplication to calculate a percentage of an amount• Find a whole amount, given a percentage of the amount• Solve percentage word problems, including problems that involve a percent increase or decrease

Unit	Objectives
Unit 11 Equations	<ul style="list-style-type: none"> • Write inequalities and equations with variables to describe real-world situations • Graph inequalities on the number line and find values of the variable that make an inequality true • Use substitution to check whether a value of a variable is a solution to an equation • Solve simple addition or multiplication equations with one variable • Write equations with two variables that show the relationship between the variables • Create a chart that shows solutions to an equation with two variables and use the chart to graph the equation on the coordinate plane • Use the graph of an equation to find solutions to the equation
Unit 12 Volume	<ul style="list-style-type: none"> • Review how to use volume formulas (length \times width \times height or base area \times height) to find volume • Divide to find the base area or height of a rectangular prism • Multiply and cancel units in volume problems • Use fractions and mixed numbers to find volume • Convert measurement units to the same unit before finding volume • Solve multi-step volume word problems
Unit 13 Surface Area	<ul style="list-style-type: none"> • Identify 3-D solids and recognize their nets • Find the surface area of 3-D solids (rectangular prisms, cubes, triangular prisms, and pyramids) • Solve real-world problems that involve surface area and volume
Unit 14 Rate and Speed	<ul style="list-style-type: none"> • Understand that a rate compares two quantities with different units • Divide to find unit rates • Solve rate problems • Use the correct units for rate problems • Solve problems involving speed, time, and distance • Solve multi-step word problems involving unit prices or speed
Unit 15 Multiply and Divide Decimals by Decimals	<ul style="list-style-type: none"> • Use mental math and decimal multiplication to find percentages of whole numbers and decimals • Multiply and divide decimals by decimals with mental math • Multiply decimals by decimals with the written algorithm • Use long division to divide decimals by decimals and round the quotient to a given number of decimal digits • Solve decimal multiplication and division word problems • Solve unit price problems with decimals • Use a calculator to multiply or divide decimals
Unit 16 Data and Statistics	<ul style="list-style-type: none"> • Find the mean, median, and mode for a data set and understand that these statistics describe the center of the data set • Describe the shape of a data set as right-skewed, left-skewed, or symmetric and use words like <i>gap</i>, <i>peak</i>, and <i>outlier</i> to describe its features • Create and interpret dot plots, histograms, and box plots • Find the range, mean absolute deviation, quartiles, and interquartile range for a data set and understand that these statistics describe the spread of the data set • Use statistics to analyze data, compare two data sets, and draw conclusions

Materials List

What You'll Need in Your Math Kit

You'll use the following materials regularly in *Sixth Grade Math with Confidence*. Stash them in a box or basket, and always keep them ready for your next lesson. (See page 8 in the Introduction for more detailed descriptions of each item.)

- 30 small counters (15 each of two different colors)
- Two packs of playing cards
- Two dice
- 1-foot (or 30-centimeter) ruler
- Highlighter
- Scrap paper
- Pencils

Other Supplies

Besides your Math Kit, you'll also need the following household items. You'll only need most of them once or twice, so you don't need to gather them ahead of time or store them separately. Check the unit overviews for the specific household items you'll need for each unit.

Items marked with an asterisk are needed for the optional enrichment lessons at the end of each unit.

- 5 dice
- 25 slips of paper
- *3 small packs of multi-colored candy, such as Skittles, M&Ms, or Smarties
- Scissors
- *Tape measure or ruler
- *Two bottles of liquid food coloring (red, yellow, or blue)
- *Water
- *6-8 small clear bowls or glasses
- *6-8 sticky notes or slips of paper
- *Holiday recipe with fractions and mixed numbers
- *Internet access, optional
- *Hot cocoa ingredients, optional
- Screw, nut, bolt, and hinge, optional
- 4 grains of rice, optional
- Base-ten blocks, optional
- *Kitchen scale
- *Several produce items of the same type (for example, 5 apples or 7 carrots)
- Colored pencils or markers
- Paper clip
- *Wad of paper and trash can, or basketball and basketball hoop
- Two pieces of paper
- Two cardboard boxes, each with at least one dimension longer than 1 foot

- *3 fruits or vegetables (like apples, oranges, or cucumbers)
- *Container large enough to hold each fruit or vegetable
- *Large, shallow baking dish
- *Large measuring cup
- Tape
- *Small box (with all dimensions less than 12 inches or 30 centimeters)
- *Aluminum foil or wrapping paper
- Timer or timer app
- *Distance tracking app, map, or map app, optional
- Calculator or calculator app
- *Sales flyer or online access to a favorite store
- 3 writing utensils or craft sticks
- Chair

Guide to the Blackline Masters

Digital Copies of Blackline Masters

Prefer to print the Blackline Masters rather than copy them from the book? Download digital copies of all Math with Confidence Blackline Masters at welltrainedmind.com/mwc.

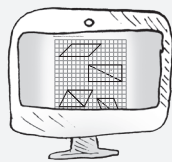

Reference Blackline Masters

Families often find it helpful to have the Memory Work pages (Blackline Master 1) available for easy reference. If possible, post these pages near your lesson area to help your child gradually memorize the items over the course of the year.

<p>Memory Work (Blackline Master 1)</p> <p>Multiplication and Division Multiples of 12, 24, 36, 48, 60. LCM stands for least common multiple. Factors of 12, 13, 2, 4, 6, 12. GCF stands for greatest common factor.</p> <p>Expressions, Equations, and Inequalities 8×6 expression $8 \times 6 = 48$ equation $8 > 6$ inequality</p> <p>Variables $3x + 5$ coefficient variable constant $3x + 5 = 8$ 3 terms</p> <p>Prime and Composite Prime numbers have exactly two factors. 2, 3, 5, 7, 11, 13, 17, 19. Composite numbers have more than two factors.</p> <p>Multiplication and Division $7 \times 9 = 63$ factors product dividend divisor quotient</p> <p>Order of Operations 1. Complete operations in parentheses. 2. Evaluate exponents. 3. Multiply or divide, from left to right. 4. Add or subtract, from left to right.</p> <p>Divisibility Rules A number is divisible by 2 if it is even. A number is divisible by 3 if the sum of its digits is divisible by 3. A number is divisible by 4 if the last two digits are divisible by 4. A number is divisible by 5 if it has 0 or 5 in the ones place. A number is divisible by 6 if it has 0 in the ones place.</p>	<p>Coordinate Plane</p> <p>Question 1 The x-coordinate tells the horizontal distance from the origin. Question 2 The y-coordinate tells the vertical distance from the origin.</p> <p>Area of a Rectangle $\text{Area} = \text{length} \times \text{width}$</p> <p>Area of a Parallelogram $\text{Area} = \text{base} \times \text{height}$</p> <p>Area of a Triangle $\text{Area} = \frac{1}{2} \times \text{base} \times \text{height}$</p> <p>Volume of a Rectangular Prism $\text{Volume} = \text{length} \times \text{width} \times \text{height}$</p> <p>3-D Solids Rectangular Prism: 8 rectangular faces Cube: 6 square faces Triangular Prism: 5 rectangular faces, 2 triangular faces, 1 face not connected to a rectangular face along each edge Pyramid: 1 face not connected to a rectangular face along each edge</p>	<p>Speed, Time, and Distance $\text{speed} \times \text{time} = \text{distance}$ $\frac{\text{distance}}{\text{time}} = \text{speed}$ $\frac{\text{distance}}{\text{speed}} = \text{time}$</p> <p>Measurement Conversion Factors 1 foot = 12 inches 1 yard = 3 feet 1 yard = 36 inches 1 mile = 5,280 feet 1 pound = 16 ounces 1 cup = 8 fluid ounces 1 centimeter = 10 millimeters 1 meter = 100 centimeters 1 kilometer = 1,000 meters 1 liter = 1,000 milliliters</p> <p>Fractions, Decimal, and Percent Equivalences</p> <table border="1"> <tbody> <tr> <td>Numerator</td> <td>$\frac{1}{2} = 0.5 = 50\%$</td> <td>$\frac{1}{5} = 0.2 = 20\%$</td> </tr> <tr> <td>Denominator</td> <td>$\frac{1}{4} = 0.25 = 25\%$</td> <td>$\frac{2}{5} = 0.4 = 40\%$</td> </tr> <tr> <td></td> <td>$\frac{3}{4} = 0.75 = 75\%$</td> <td>$\frac{3}{5} = 0.6 = 60\%$</td> </tr> <tr> <td></td> <td>$\frac{1}{3} = 33\frac{1}{3}\%$</td> <td>$\frac{2}{3} = 66\frac{2}{3}\%$</td> </tr> <tr> <td></td> <td>$\frac{1}{6} = 16\frac{2}{3}\%$</td> <td>$\frac{5}{6} = 83\frac{1}{3}\%$</td> </tr> </tbody> </table> <p>Mean The mean (average) is the sum of the values divided by the number of values.</p> <p>Median The median is the middle value when the values are in order from least to greatest.</p> <p>Mode The mode is the value that occurs most frequently.</p> <p>Range The range is the difference between the greatest and least values.</p> <p>Mean Absolute Deviation (MAD) The mean absolute deviation measures how far each data point is from the mean.</p> <p>Five-Number Summary The five-number summary for a data set includes the minimum, first quartile (Q1), median, third quartile (Q3), and maximum.</p> <p>Interquartile Range (IQR) The interquartile range measures the spread of the middle 50% of the values in a data set.</p>	Numerator	$\frac{1}{2} = 0.5 = 50\%$	$\frac{1}{5} = 0.2 = 20\%$	Denominator	$\frac{1}{4} = 0.25 = 25\%$	$\frac{2}{5} = 0.4 = 40\%$		$\frac{3}{4} = 0.75 = 75\%$	$\frac{3}{5} = 0.6 = 60\%$		$\frac{1}{3} = 33\frac{1}{3}\%$	$\frac{2}{3} = 66\frac{2}{3}\%$		$\frac{1}{6} = 16\frac{2}{3}\%$	$\frac{5}{6} = 83\frac{1}{3}\%$
Numerator	$\frac{1}{2} = 0.5 = 50\%$	$\frac{1}{5} = 0.2 = 20\%$															
Denominator	$\frac{1}{4} = 0.25 = 25\%$	$\frac{2}{5} = 0.4 = 40\%$															
	$\frac{3}{4} = 0.75 = 75\%$	$\frac{3}{5} = 0.6 = 60\%$															
	$\frac{1}{3} = 33\frac{1}{3}\%$	$\frac{2}{3} = 66\frac{2}{3}\%$															
	$\frac{1}{6} = 16\frac{2}{3}\%$	$\frac{5}{6} = 83\frac{1}{3}\%$															

Short-Term-Use Blackline Masters

You will use these Blackline Masters for only a few lessons. You do not need to save them after you finish the corresponding unit.

- Paper Shapes (Blackline Master 2), used in Unit 3 only
- Paper Fraction Circles (Blackline Master 3), used in Unit 7 only
- Percent Square (Blackline Master 4), used in Unit 10 only
- Nets (Blackline Master 5), used in Unit 13 only
- Rectangular Prisms (Blackline Master 6), used in Unit 13 only

Optional Blackline Masters

The lessons in Units 8, 10, and 15 occasionally suggest using base-ten blocks to model percentage and decimal concepts. The following Blackline Master is provided in case you want to use these suggestions and do not own real base-ten blocks.

- Base-Ten Blocks (Blackline Master 7)

Memory Work (Blackline Master 1)

Multiples and Factors

Multiples of 12: 12, 24, 36, 48, 60...

LCM stands for least common multiple.

Factors of 12: 1, 2, 3, 4, 6, 12

GCF stands for greatest common factor.

Expressions, Equations, and Inequalities

8×6	$8 \times 6 = 48$	$8 > 6$
expression	equation	inequality

Variables

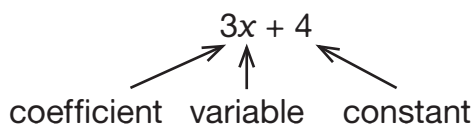

$$\begin{array}{ccc}
 2a + b + 6 & & \\
 \text{3 terms} & &
 \end{array}$$

Prime and Composite

Prime numbers have exactly two factors.

2, 3, 5, 7, 11, 13, 17, 19...

Composite numbers have more than two factors.

Multiplication and Division

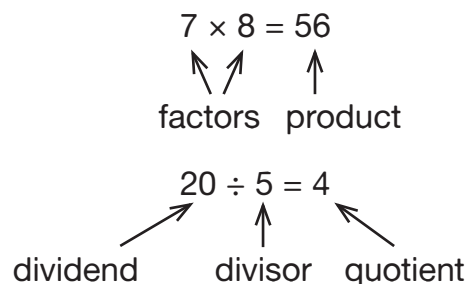

Order of Operations

1. Complete operations in parentheses.
2. Evaluate exponents.
3. Multiply or divide, from left to right.
4. Add or subtract, from left to right.

Divisibility Rules

A number is divisible by **2** if it is even.

A number is divisible by **3** if the sum of its digits is divisible by 3.

A number is divisible by **4** if you get an even quotient when you divide it by 2.

A number is divisible by **5** if it has 0 or 5 in the ones-place.

A number is divisible by **6** if it is even and divisible by 3.

A number is divisible by **10** if it has 0 in the ones-place.

Coordinate Plane

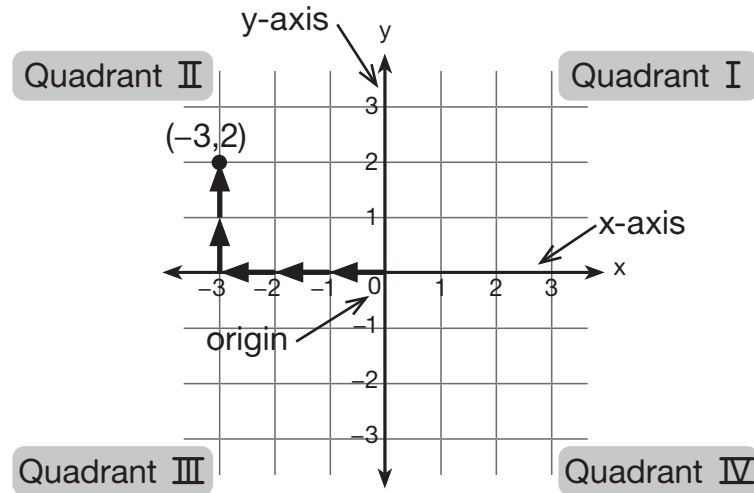

The **x-coordinate** tells the horizontal distance from the origin.

The **y-coordinate** tells the vertical distance from the origin.

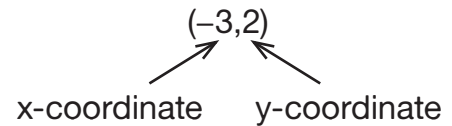

Area of a Rectangle

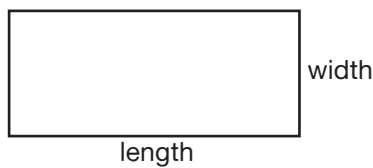

$$\text{Area} = \text{length} \cdot \text{width}$$

Area of a Parallelogram

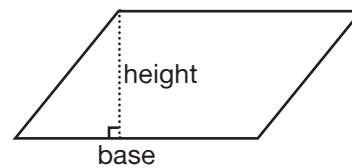

$$\text{Area} = \text{base} \cdot \text{height}$$

Area of a Triangle

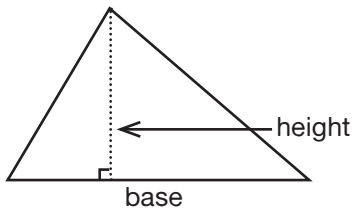

$$\text{Area} = \frac{\text{base} \cdot \text{height}}{2}$$

$$\text{Area} = \frac{1}{2} \cdot \text{base} \cdot \text{height}$$

Volume of a Rectangular Prism

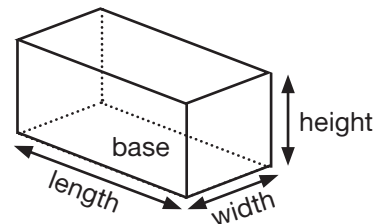

$$\text{Volume} = \text{length} \cdot \text{width} \cdot \text{height}$$

$$\text{Volume} = \text{base area} \cdot \text{height}$$

3-D Solids

Rectangular Prism

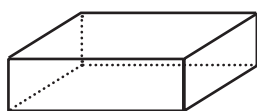

6 rectangular faces

Cube

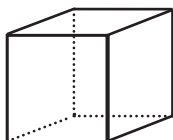

6 square faces

Triangular Prism



2 triangular faces, connected by 3 rectangular faces

Pyramid

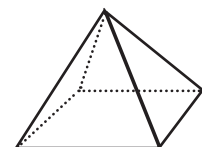

1 flat face, connected to a triangular face along each side

Speed, Time, and Distance

$$\text{speed} \times \text{time} = \text{distance}$$

$$\frac{\text{distance}}{\text{time}} = \text{speed}$$

$$\frac{\text{distance}}{\text{speed}} = \text{time}$$

Measurement Conversion Factors

$$1 \text{ foot} = 12 \text{ inches}$$

$$1 \text{ yard} = 3 \text{ feet}$$

$$1 \text{ yard} = 36 \text{ inches}$$

$$1 \text{ mile} = 5,280 \text{ feet}$$

$$1 \text{ pound} = 16 \text{ ounces}$$

$$1 \text{ cup} = 8 \text{ fluid ounces}$$

$$1 \text{ centimeter} = 10 \text{ millimeters}$$

$$1 \text{ meter} = 100 \text{ centimeters}$$

$$1 \text{ kilometer} = 1,000 \text{ meters}$$

$$1 \text{ kilogram} = 1,000 \text{ grams}$$

$$1 \text{ liter} = 1,000 \text{ milliliters}$$

Fractions

$$\frac{2}{5}$$

← Numerator
 ← Denominator

To find the **reciprocal** of a fraction, flip the positions of the numerator and denominator.

$$\frac{2}{5} \leftrightarrow \frac{5}{2}$$

Fraction, Decimal, and Percent Equivalencies

$$\frac{1}{2} = 0.5 = 50\%$$

$$\frac{1}{5} = 0.2 = 20\%$$

$$\frac{1}{4} = 0.25 = 25\%$$

$$\frac{2}{5} = 0.4 = 40\%$$

$$\frac{3}{4} = 0.75 = 75\%$$

$$\frac{3}{5} = 0.6 = 60\%$$

$$\frac{1}{3} = 33 \frac{1}{3}\%$$

$$\frac{4}{5} = 0.8 = 80\%$$

$$\frac{2}{3} = 66 \frac{2}{3}\%$$

Data

The **mean** (average) is the sum of the values divided by the number of values.

The **median** is the middle value when the values are in order from least to greatest.

The **mode** is the value that occurs most frequently.

The **mean absolute deviation** measures how much the values in the data set deviate (or vary) from the mean.

The **five-number summary** for a data set includes the minimum, lower quartile (Q1), median (Q2), upper quartile (Q3), and maximum.

Interquartile range measures the range for the middle 50% of the values in a data set.

Paper Shapes (Blackline Master 2)

Directions: Cut out along the dark lines.

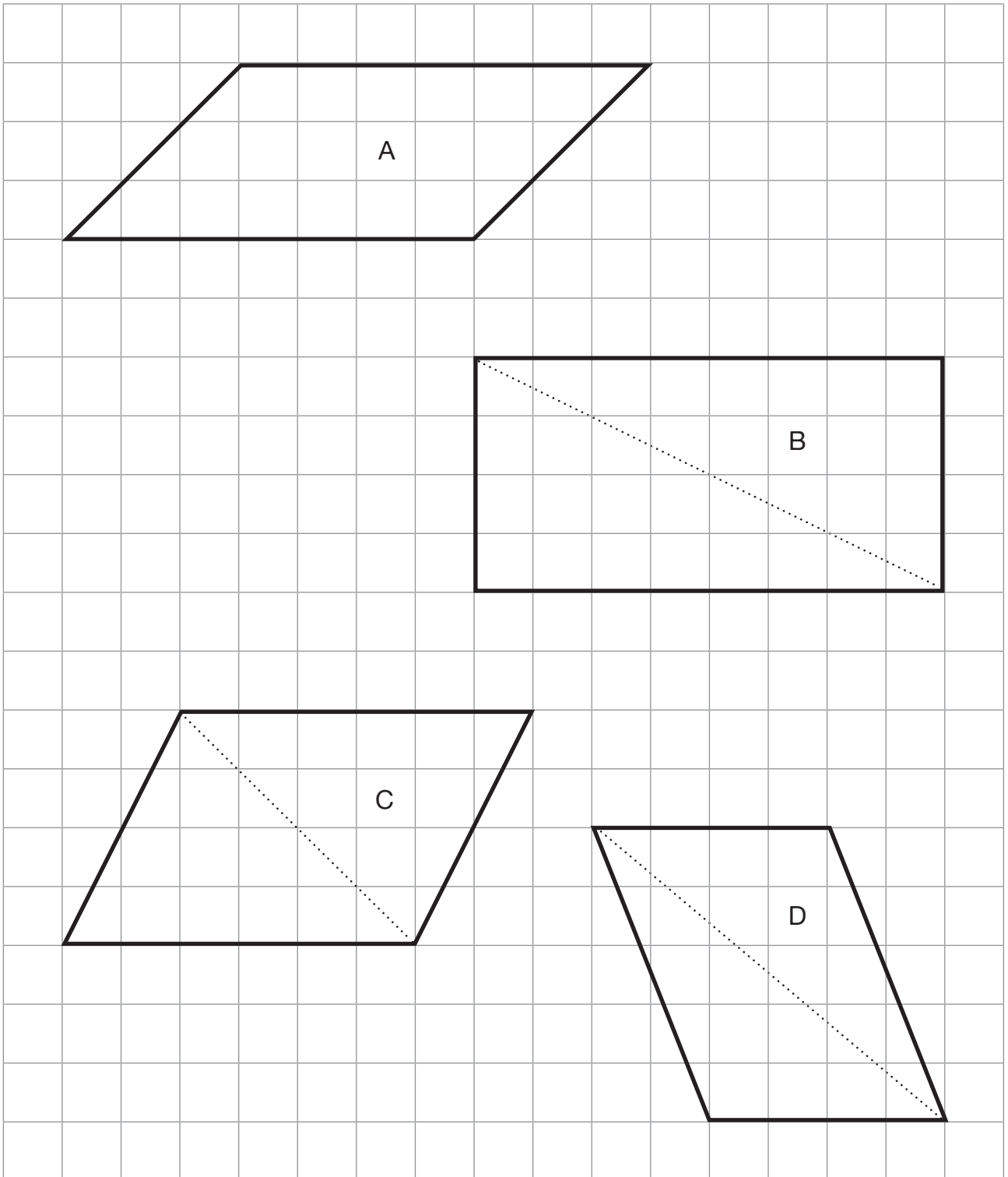

Paper Fraction Circles (Blackline Master 3)

Directions: Cut out the circles on the solid lines.

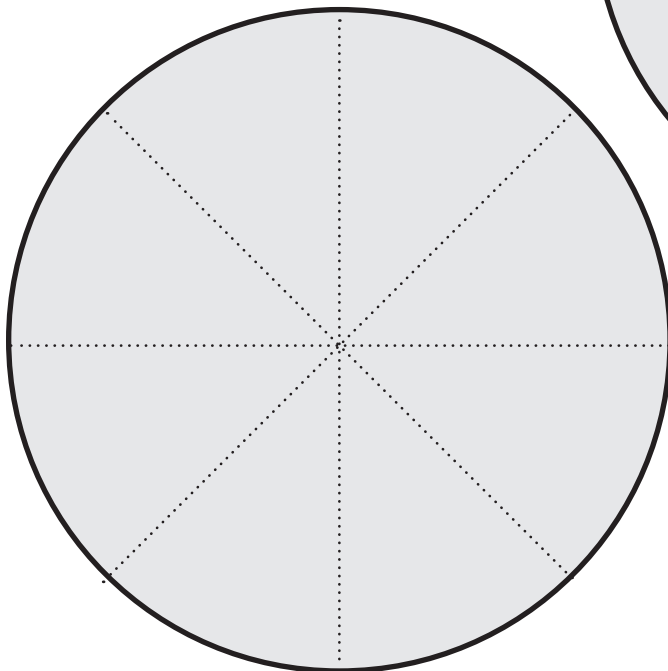
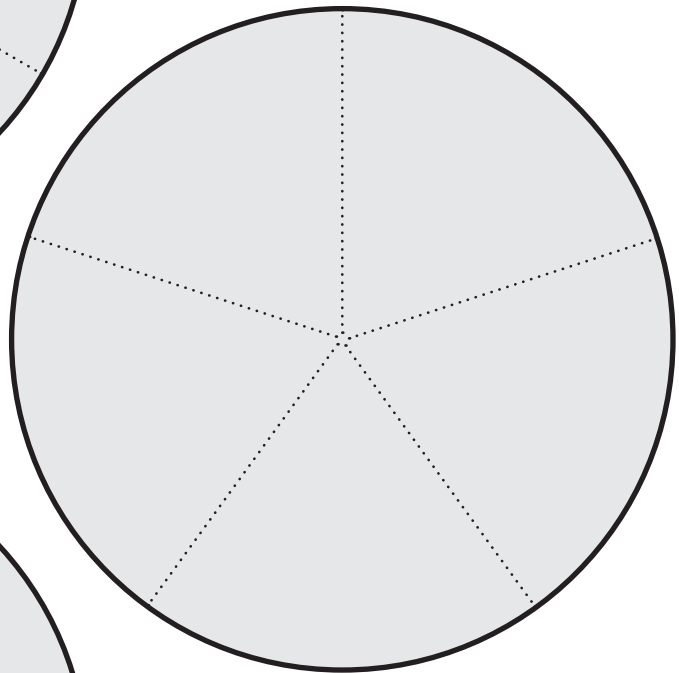
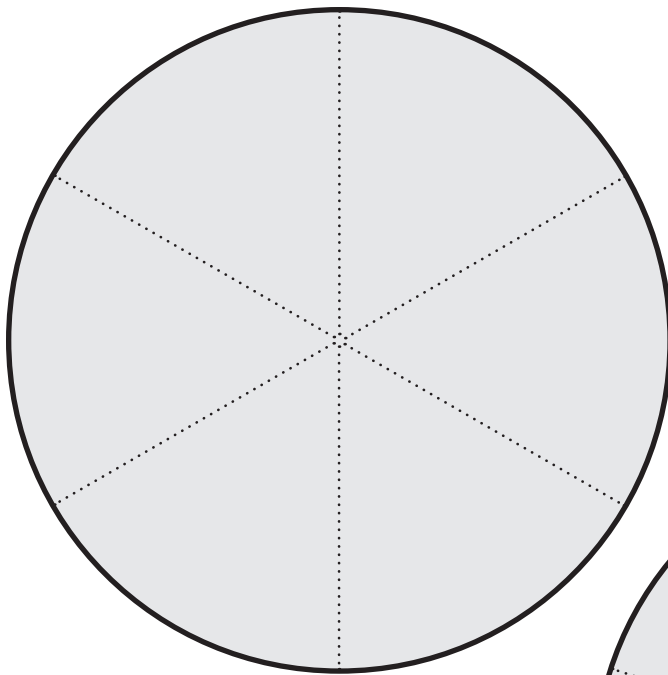

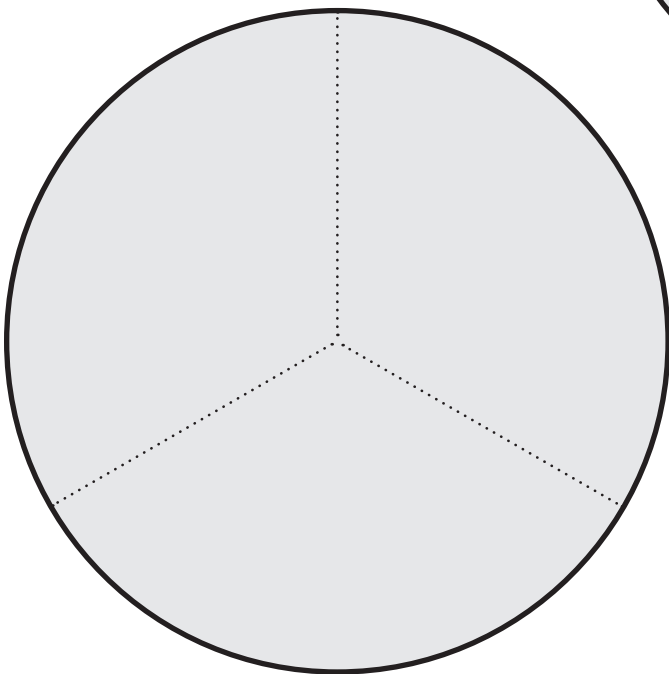
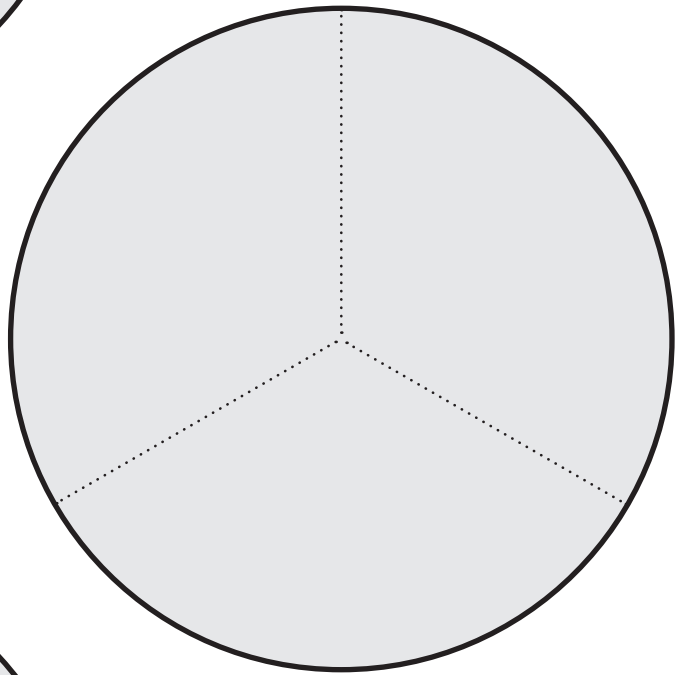
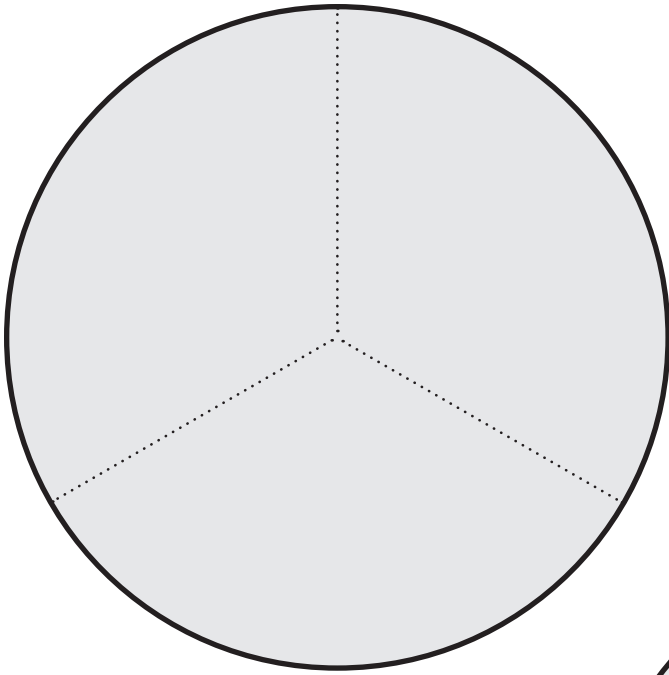

Percent Square (Blackline Master 4)

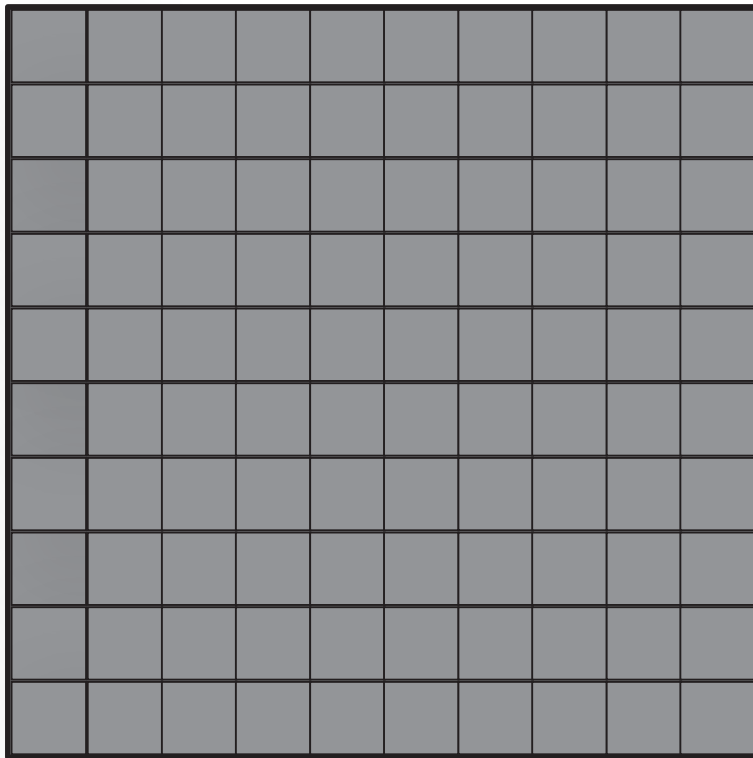

Nets (Blackline Master 5)

Directions: Copy these pages onto sturdy paper. Cut out along the solid lines.

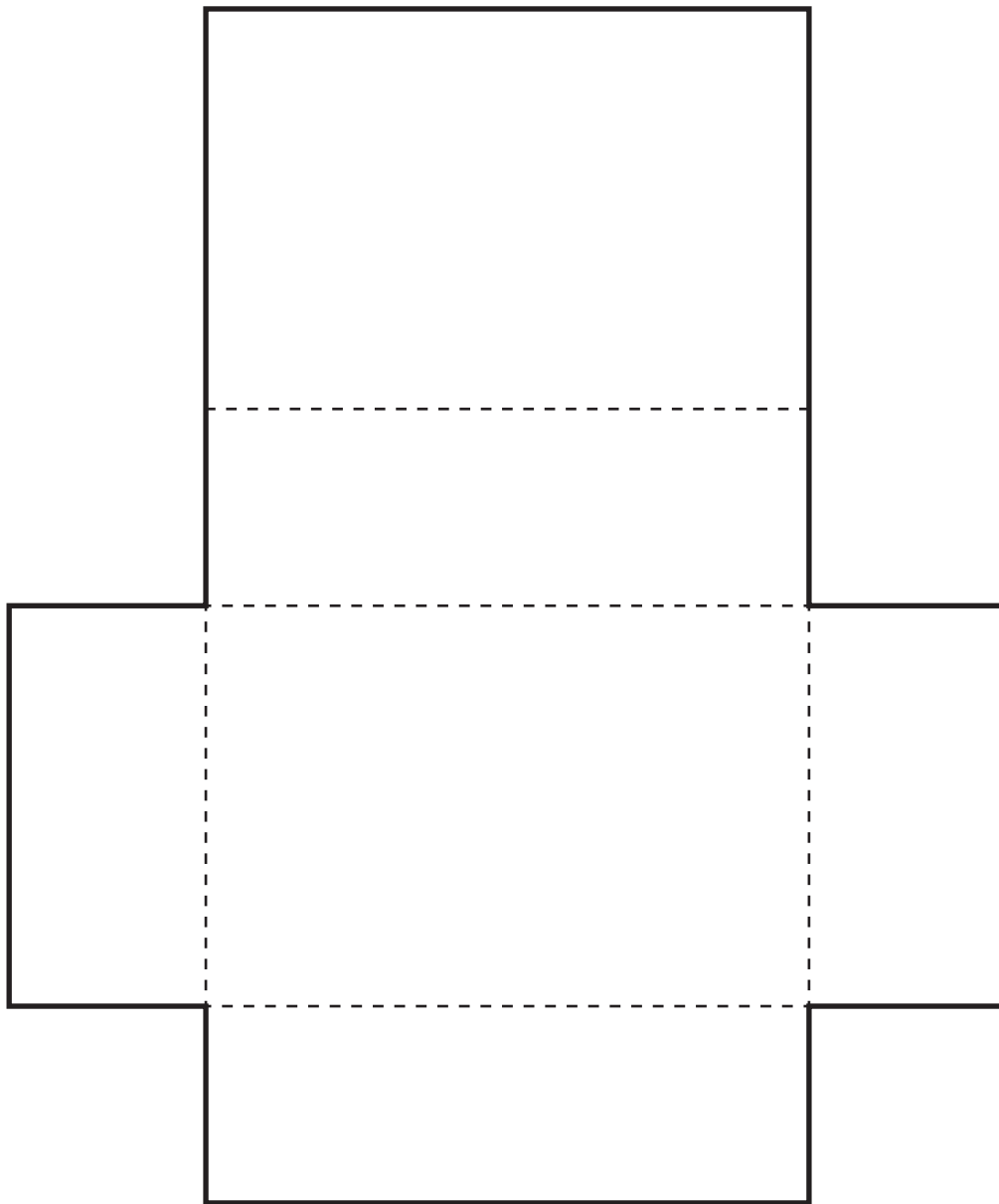

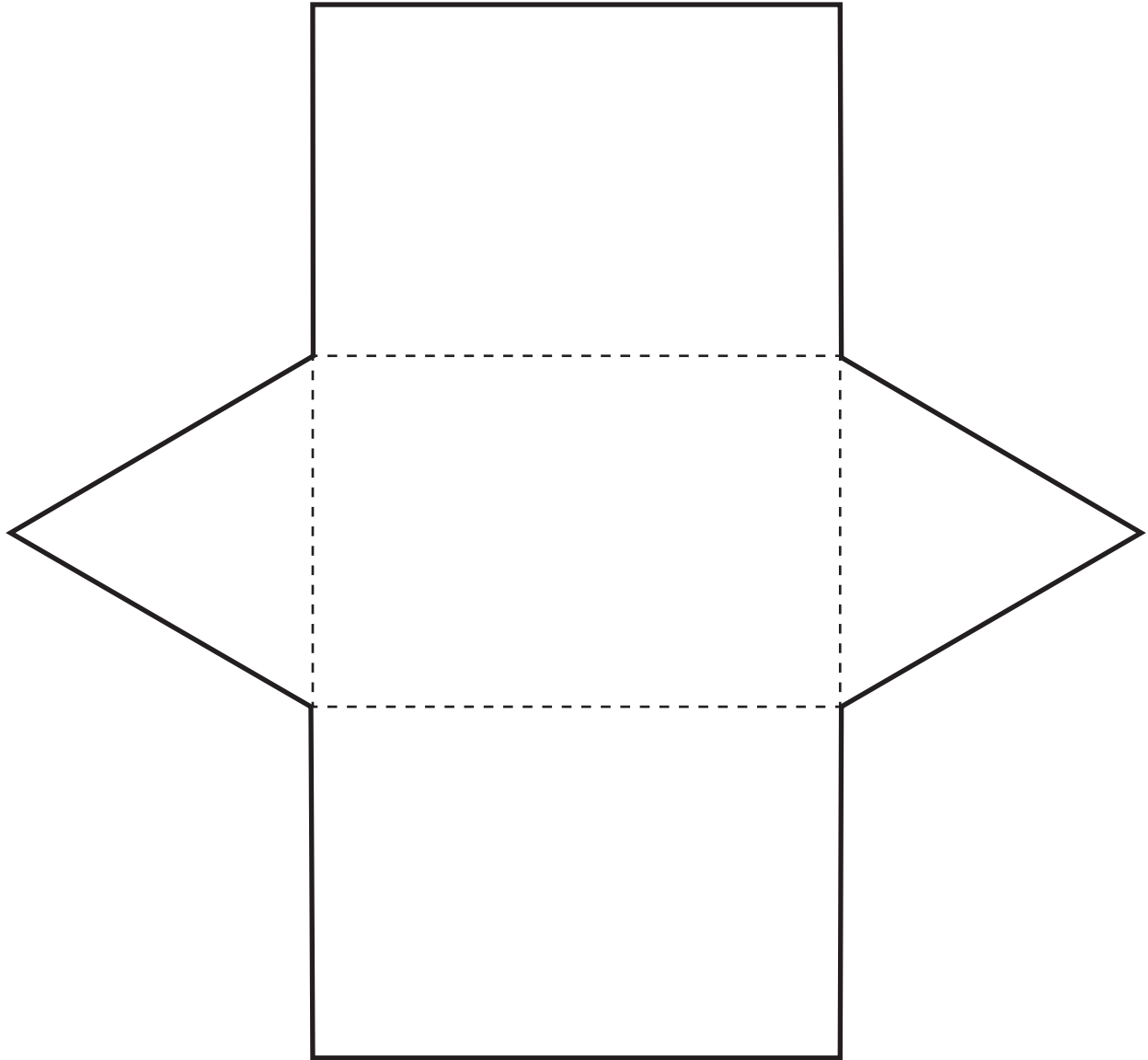

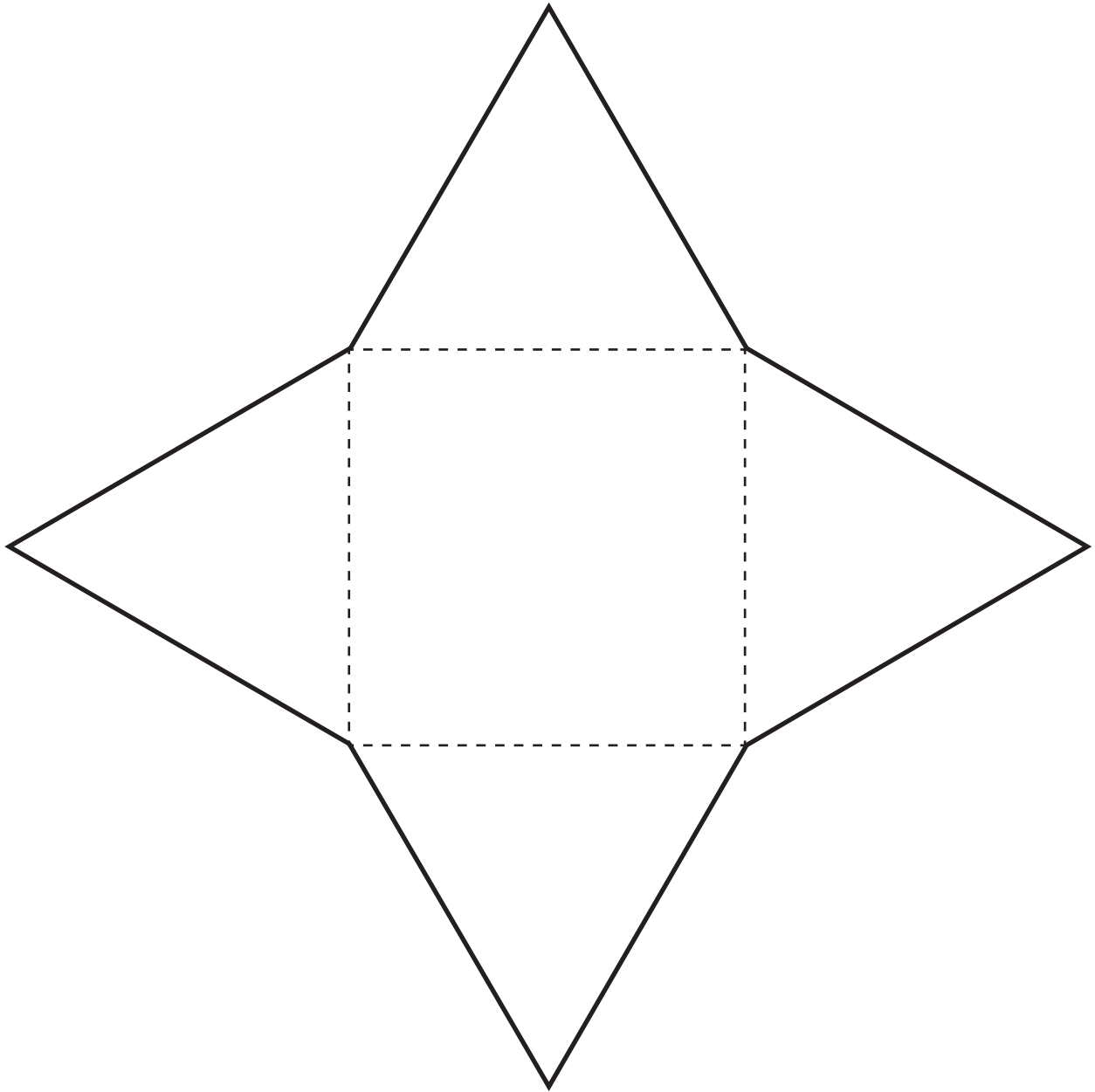

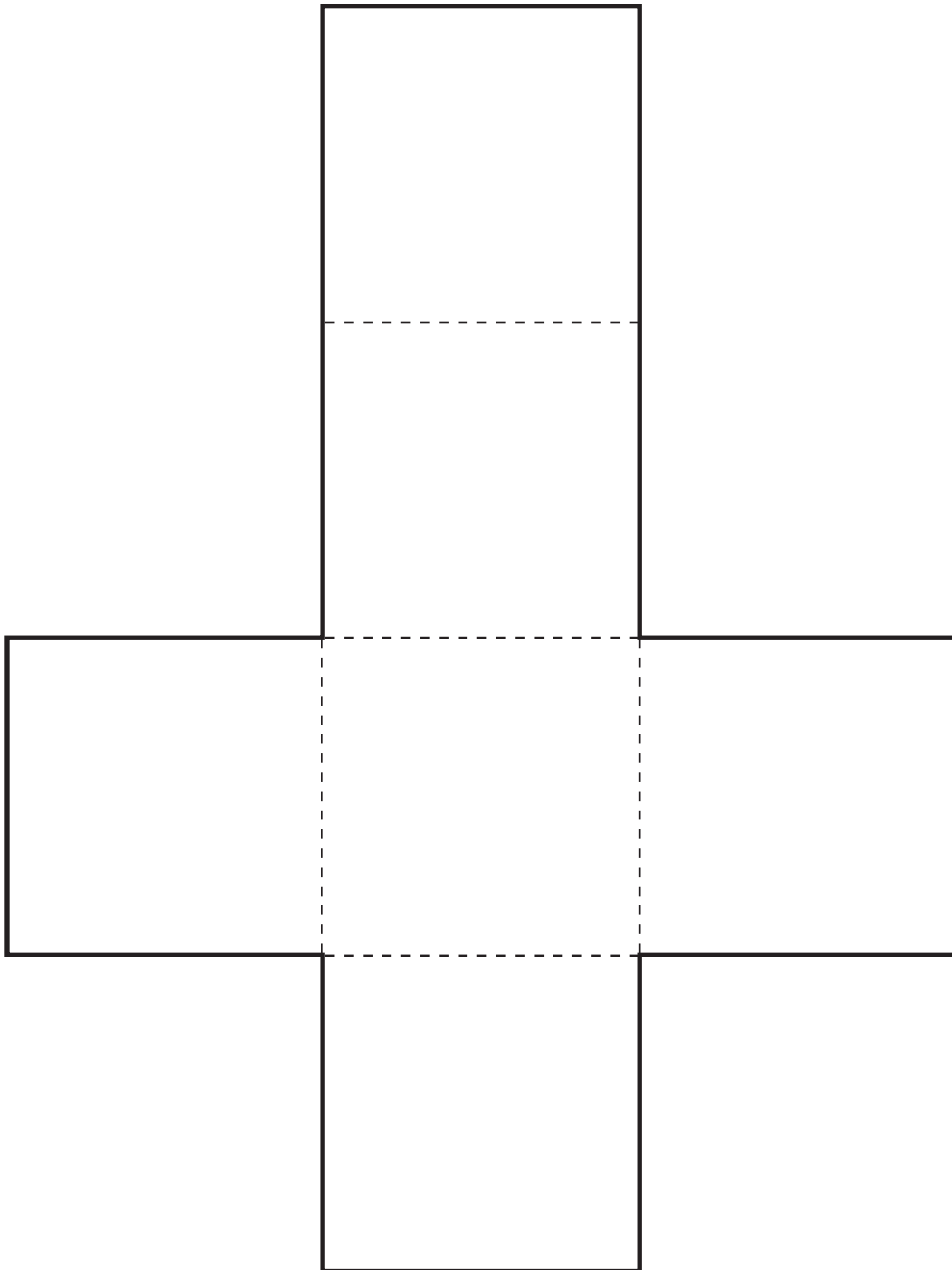

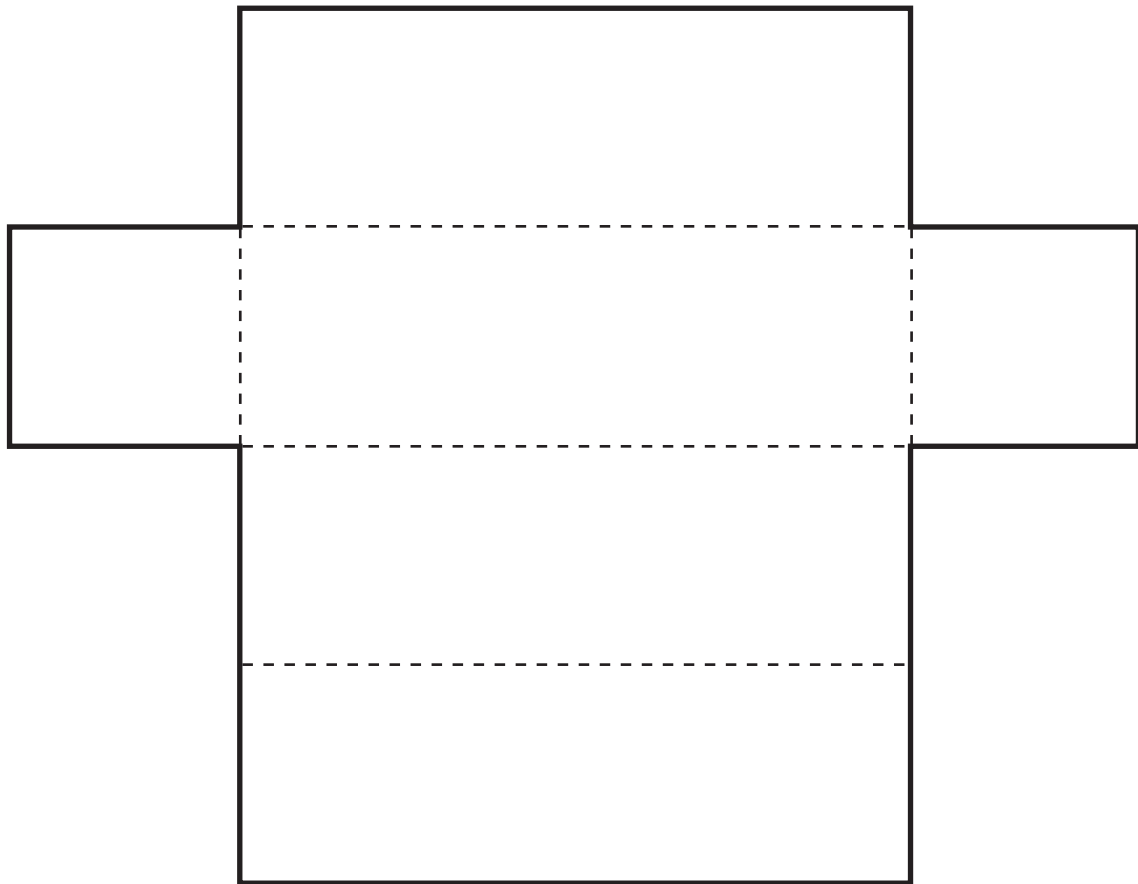

Rectangular Prisms (Blackline Master 6)

Directions: Copy onto sturdy paper. Cut out along the solid lines.

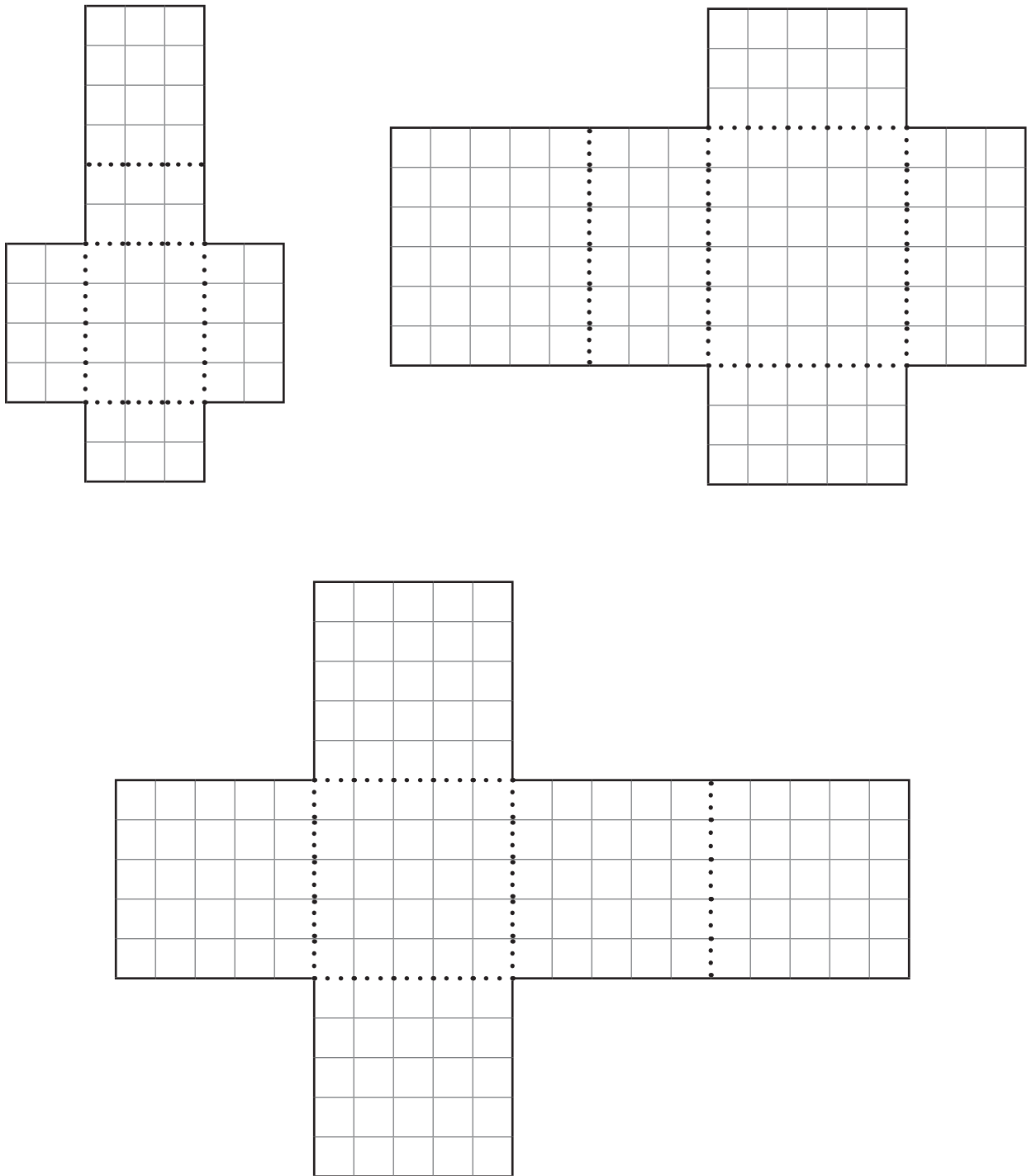

Base-Ten Blocks (Blackline Master 7)

Optional. See page 518 for more details about whether you need this page.

Directions: Make 3 copies of this page on sturdy paper. Cut out the blocks along the dark lines.

